



DRAFT

BSR E1.79 - 202x
Entertainment Industry Electrical Practices in Canada

Approved by the ANSI Board of Standards Review on _____

EP/2024-7001r2

© 202x Entertainment Services and Technology Association (ESTA)
All rights reserved.

Notice and Disclaimer

ESTA does not approve, inspect, or certify any installations, procedures, equipment or materials for compliance with codes, recommended practices or standards. Compliance with an ESTA standard or recommended practice is the sole and exclusive responsibility of the manufacturer or provider and is entirely within their control and discretion. Any markings, identification or other claims of compliance do not constitute certification or approval of any type or nature whatsoever by ESTA.

ESTA neither guaranties nor warrants the accuracy or completeness of any information published herein and disclaim liability for any personal injury, property or other damage or injury of any nature whatsoever, whether special, indirect, consequential or compensatory, directly or indirectly resulting from the publication, use of, or reliance on this document.

In issuing and distributing this document, ESTA does not either (a) undertake to render professional or other services for or on behalf of any person or entity, or (b) undertake any duty to any person or entity with respect to this document or its contents. Anyone using this document should rely on their own independent judgment or, as appropriate, seek the advice of a competent professional in determining the exercise of reasonable care in any given circumstance.

Published By:

Entertainment Services and Technology Association (ESTA)
271 Cadman Plaza PO Box 23200
Brooklyn, NY 11202-3200
USA
Phone: +1-212-244-1505
Email: standards@esta.org

ESTA's Technical Standards Program

ESTA's Technical Standards Program was created to serve the ESTA membership and the entertainment industry in technical standards-related matters. The goal of the program is to take a leading role regarding technology and safety within the entertainment industry by creating recommended practices and standards, monitoring standards issues around the world on behalf of our members, and improving communications and safety within the industry. In its technical standards development activities, ESTA works closely with other industry organizations, including ESA, CITT, USITT and VPLT, in addition to representing the interests of ESTA members to ANSI, UL, ASCE, ICC, and NFPA. ESTA is an ANSI Accredited Standards Developer.

The Technical Standards Council (TSC) established by ESTA's Board of Directors to oversee and coordinate the Technical Standards Program. Made up of individuals experienced in standards development work from throughout our industry, the Committee approves all projects undertaken and assigns them to the appropriate working group. The Technical Standards Council employs a Technical Standards Manager to coordinate the work of the Committee and its working groups as well as maintaining a "Standards Watch" on behalf of members. Working groups include: Control Protocols, Electrical Power, Event Safety, Floors, Fog and Smoke, Followspot Positions, Mental Health & Well-being Management, Photometrics, Rigging, Stage Machinery, and Prop Weapons Safety.

ESTA encourages active participation in the Technical Standards Program. There are several ways to become involved. The easiest way to actively participate is to respond to any of the public reviews advertised on ESTA's [public review web page](#). The next level of participation requires completion of an application to become a working group member; applications are available from the TSP's [procedural documents web page](#). Application as an Observer with non-voting status affords access to updates on standards development documents. Application as a voting participant affords full access to a consensus voice that helps shape the industry. Voting status carries responsibilities of responding to letter ballots and attending meetings, but membership in ESTA or any other organization is not a requirement for participation in the TSP. One can also become involved by requesting that the TSC develop a standard or a recommended practice in an area of concern to them.

The Electrical Power Working Group, which authored this standard, consists of a cross section of entertainment industry professionals representing a diversity of interests. ESTA is committed to developing consensus-based standards and recommended practices in an open setting.

Investors in Innovation

The Technical Standard Program (TSP) is financially supported by ESTA and by companies and individuals who make donations to the TSP. Contributing companies and individuals who have helped fund the TSP are recognized as "Investors in Innovation". The Investors in Innovation when this standard was approved by ANSI's Board of Standards Review are gratefully acknowledged as follows:

[Insert the current Investors table here. Source from latest Swatch Edition]

Memorial donor: The Estate of Ken Vannice

All donations to the Technical Standards Program benefit the entire program, and are not directed to any specific use or project within the program. Please help support the Technical Standards Program by becoming an Investor in Innovation. Visit our website at <http://tsp.esta.org/invest>, or contact the ESTA office at 1-212-244-1505 and select "TSP" from the menu.

Contact Information**Technical Standards Manager**

Richard J. Nix
ESTA
271 Cadman Plaza PO Box 23200
New York, NY 11202-3200
USA
+1-212-244-1505
richard.nix@esta.org

Technical Standards Council Co-chairpersons

Alan Rowe
I.A.T.S.E Local 728
+1-310-702-2909
amrowe@iatse728.org

Dan Culhane
Wenger Corp
+1-612-868-4769
culhane.dan@gmail.com

Electrical Power Working Group Co-chairpersons

Justin Bennett
University of the Incarnate Word
+1-210-829-3809
jbennett@uiwtx.edu

Mitch Hefter
+1-972-839-8488
mitch@mitchhefter.com

Acknowledgments

The Electrical Power Working Group members, when this document was approved by the working group on [insert date], are gratefully acknowledged below.

Voting members:**Observer (non-voting) members:****Interest category codes:**

CP = custom-market producer DE = designer
DR = dealer rental company G = general interest
MP = mass-market producer U = user

Table of Contents

Notice and Disclaimer.....	i
Investors in Innovation.....	iii
Contact Information.....	iv
Acknowledgments.....	v
Table of Contents.....	vi
1 Scope.....	1
2 Introductory Notes.....	1
3 Definitions.....	1
4 General Practices.....	7
4.1 Permit.....	7
4.2 Reporting of Serious Electrical Accidents or Incidents.....	7
4.3 Personnel.....	7
4.4 Equipment Approval.....	8
4.5 Operations.....	8
5 Power Sources.....	10
5.1 General.....	10
5.2 Utility Sources.....	11
5.3 Generator Sets and Alternate Power Sources.....	12
6 Power Distribution.....	14
6.1 General.....	14
6.2 Single Conductor Distribution.....	15
6.3 Multiconductor Distribution.....	22
6.4 Distribution Equipment.....	23
6.5 Cable Protection.....	26
6.6 Cable Strain Relief.....	26
7 Utilisation.....	27
7.1 Location of Utilisation Equipment.....	27
7.2 Luminaires.....	27
7.3 Luminaire Handling.....	28
7.4 Support Equipment Battery Charging (not exceeding 24 V and 24 Ah).....	28
Appendices.....	29
Appendix A – Accepted Certification Marks.....	29
Appendix B – Accepted Field Approval Marks (to SPE-1000).....	32
Appendix C - Component Certification Marks.....	34
Appendix D – European Union and British Marks*.....	34
Appendix E - Allowable Ampacity of Flexible Insulated (Multiconductor) Copper Cord.....	35
Appendix F - Dual Circuit Fed Receptacle.....	36
Appendix G - The Use of Three Phase Distribution Equipment on Single Phase Three Wire Sources.....	37
Appendix H – Correct Mating of Cam-type Single-Pin Connectors.....	38
Appendix J – Twofers (Y cords).....	39
Appendix K - Single-Pin Connectors Utilised at Greater Than 150 Volts to Ground.....	41
Appendix L – Doorway Insert - Example.....	42
Appendix M – Industry C of Q Designations.....	43
Appendix N - Reference Standards and Guidelines.....	44
Tables.....	45
Table 1 - Overcurrent Protection for Portable Power Cable *.....	45
Table 2 - 19 Pin Circular Connector Pin Designation – ANSI E1.80 120V Type U.....	45
Table 2A - 19 Pin Circular Connector Designations.....	46
Table 2A - Marking Examples.....	47

1 Scope

This standard deals with the temporary implementation and utilisation of portable electrical equipment in the entertainment industry, utilising any source of power including generator sets and alternate power sources and is intended for use by industry technicians, employers, and the Authority Having Jurisdiction (AHJ). This includes events of a temporary nature held indoors, outdoors, in tents, but is not restricted to:

- (a) amusement parks;
- (b) carnivals;
- (c) fairs;
- (d) midways;
- (e) concerts;
- (f) live performance and entertainment events;
- (g) touring shows and productions;
- (h) film, television, and radio productions;
- (i) remote broadcasting and recording locations;
- (j) sporting events; and
- (k) trade shows.

2 Introductory Notes

2.1 Throughout this Standard “CEC” or “Code” means the Canadian Electrical Code Part 1.

*Note: may show up in other areas expressed as CE Code.
Should not be confused with the EU industry standard CE mark.
Refer also to Appendix D – British and European Union Marks.*

2.2 References to relevant Code rules, approval and certification marks are current as of the time of the release of this standard.

2.3 On some practices the Code is silent. This Standard delineates methods which are required to safely achieve objectives in the entertainment industry. Accepted practices in many jurisdictions may require AHJ consultation in other jurisdictions.

2.4 Practices which may require AHJ consultation are identified with a **AHJ** symbol.

2.5 In this Standard, “shall” or “must” are used to express a requirement, i.e., a provision that the user is obliged to satisfy in order to comply with the standard; “should” is used to express a recommendation or that which is advised but not required; and “may” is used to express an option or that which is permissible within the limits of the standard.

2.6 Notes accompanying clauses do not include requirements or alternative requirements; the purpose of a note accompanying a clause is to separate from the text explanatory or informative material.

2.7 Notes to tables and figures are considered part of the table or figure and may be written as requirements.

2.8 Appendices are designated normative (mandatory) or informative (non-mandatory) to define their application.

2.9 References to appendices or to specific sections are to those in this Standard. External references are as identified.

2.10 All units, measurement references, measurement specifications are in the SI system with Imperial units (where utilised) in parentheses.

2.11 All wire gauge references are exclusively to copper conductors.

3 Definitions

3.1 **AHJ**: An AHJ or Authority Having Jurisdiction is the organization, office, or individual having statutory responsibility for enforcing the requirements of a standard in the area where the activity takes place. **AHJ**

3.2 AWG: American Wire Gauge

3.3 Adaptor: a device or cordset used to make a connection between non-mating connectors.

3.4 Alternate Power Source (APS): a source of line voltage alternating current power derived from other than utility power.

Note: may be a generating set or battery pack(s) with inverter.

3.5 Ampacity: is the current carrying capacity of electrical conductors or equipment expressed in amperes.

3.6 Apprentice (Registered Trainee): recognized indentured worker, training to become a tradesperson holding a Certificate of Qualification. Able to perform assigned tasks under direct supervision of appropriate responsible certificate holder.

3.7 Approval - Electrical: assessment and acceptance of equipment evaluated using the model code for field evaluation of electrical equipment (SPE-1000). Does not entail laboratory testing to an applicable product standard.

(Refer to Appendix B - Accepted SPE-1000 Field Approval Marks)

3.8 Ballast: a resistor, transformer, or electronic circuit used to limit the current to a discharge type of light source. Typically used with fluorescent tubes, HID, HMI, CID, XENON, etc. luminaires.

3.9 Bonding: a low impedance path obtained by permanently joining all non-current-carrying metal parts to ensure electrical continuity and having the capacity to conduct safely any current likely to be imposed on it.

3.10 Bonding conductor (bond): a conductor that connects the non-current-carrying parts of electrical equipment, raceways, or enclosures to the service equipment or the system grounding conductor.

3.11 Branch circuit: that portion of the electrical system after the final overcurrent device protecting the circuit.

3.12 Break-in: A socket multi-pin circular connector with plug connectors. Incorrectly referred to as “splay” in certain regions. The 19-Pin circular connector is used to combine or separate individual circuits into or out of multiconductor cable. (Refer to 3.13 Break-out)

3.13 Break-out: A plug multi-pin circular connector with socket connectors to supply power to instruments or other electrical devices. Incorrectly referred to as “splay” in certain regions.

3.14 C of Q: A term describing the Certificate of Qualification as issued by the relevant Provincial body for a specific pertinent trade. Also includes Interprovincial “Red Seal” trades.

(Refer to Appendix M - Industry C of Q Designations)

3.15 CSA: the Canadian Standards Association, as accredited by the Standards Council of Canada, sets standards for safe construction of electrical equipment. It also inspects and identifies equipment that meets the standards.

3.16 Cable (Electrical or Power): A manufactured assembly used for transmission of electricity, consisting of one or more insulated conductors with insulating and protective material.

3.17 Cam-type Single-Pin: refer to “Single-Pin” definition.

3.18 Canadian Electrical Code (CEC): national electrical code which provides the basis for all Provincial or Territorial electrical codes with their respective amendments and/or supplements which are adopted into law in those jurisdictions.

3.19 Certification – Electrical: accredited laboratory testing and acceptance of equipment evaluated using an applicable CSA product standard and bearing a valid and appropriate certification mark.

(Refer to Appendix A – Accepted Certification Marks)

- 3.20 Certification Organization:** a “certification body” accredited in accordance with the Standards Council of Canada Act.
- 3.21 Certified person:** a holder of a valid certificate of qualification applicable to the work being performed.
- 3.22 Circuit:** A complete path from the source to the load and back to the source.
- 3.23 Circular Connector - 19 pin:** a SL419 compatible 19 pin circular connector with locking ring and multiconductor cable utilising these connectors. Refers to both cable and connector type. Commonly referred to as “Soca”.
- 3.24 Conductor:** a wire or cable, or other form of metal, installed for the purpose of conveying electric current from one piece of electrical equipment to another or to ground.
- 3.25 Connector (wire):** a device that connects two or more conductors together or one or more conductors to a terminal point for the purpose of connecting electrical circuits.
- 3.26 Company Panel/Switch:** a dedicated electrical supply device, up to 400 A, provided in theatres, event venues, film and television production studios, for the connection of portable power systems.
- 3.27 Component (electrical):** Electrical components are those which may have restrictions on their performance or may be incomplete in construction and are intended to be used as part of a larger approved product or system.
- 3.28 Cordset:** an assembly consisting of a suitable length of flexible cord or power supply cable provided with an attachment plug (plug connector) at one end and a cord connector (socket connector) at the other end.
- 3.29 Damp Location:** an exterior or interior location that is normally or periodically subject to condensation of moisture in, on, or adjacent to electrical equipment and includes partially protected locations under canopies, marquees, roofed open porches, and similar locations (per CEC Definitions).
- 3.30 Device:** generally installed in an outlet box individually or in multi-outlet assemblies to provide control of or to provide power to apparatus through a switch(s), outlet(s), or spliced junction(s) with a protective cover.
- 3.31 Device Box/Outlet Box:** Boxes in a variety of shapes and sizes used to house electrical devices such as switches, outlets, junctions or light fixtures with a protective cover. Device/outlet boxes are available in metal and plastic.
- 3.32 Disconnect:** a device, or group of devices, whereby the conductors of a circuit can be isolated (disconnected) from their source of supply.
- 3.33 Distribution Box – Electrical (Distro):** a device that permits the branching of power to two or more downstream devices; either loads or additional distribution boxes. Generally consisting of single-pin, studio connector, or pin and sleeve line connectors, with circuit breaker(s) (or fuse(s)) overcurrent protection feeding socket load connectors.
- 3.34 Electrician (Trade):** a trades person, with a Certificate of Qualification (C of Q) under the National Occupational Classification (NOC) 72200.
- 3.35 Emergency lighting:** lighting required by the provisions of the National Building Code of Canada for the purpose of facilitating safe exit and access to exit in the event of fire or other emergency.
- 3.36 Equipment Certification - Electrical:** refer to definition for Certification – Electrical.
- 3.37 Equipotential:** the state in which conductive parts are at a substantially equal electric potential.
- 3.38 Event:** a gathering, presentation, production, performance or activity for entertainment, business, education, sporting competitions, etc., utilising production equipment and practices as a part of the event, such as equipment assembled, operated and disassembled by entertainment technical personnel.

3.39 Feeder: any portion of an electrical circuit between the source of supply and the branch circuit overcurrent devices, generally single conductor cables with single-pin connectors.

3.40 Field Approval - Electrical: refer to definition for Approval - Electrical

3.41 Flown equipment: Equipment suspended by a length of chain, rope, cable or other extension from an anchor point. Could be fixed or movable.

3.42 Generator Set (Genset) (aka Generator): An assembly consisting of a prime mover, an alternator or DC generator, overcurrent devices, and load connections or receptacles that are assembled and connected on a common machine frame, often packaged in an acoustical enclosure.
(Refer to CSA C22.2 NO. 100:14, Motors and Generators)

3.42.1 Mobile Generator: A mobile or vehicle mounted generator set that exceeds the rating of a portable generator in CSA C22.2 NO. 100:14, Motors and Generators.

3.42.2 Portable Generator: a generator rated at not more than 12 kW and 240 V, intended to be used as an isolated system for the supply of cord connected electrical equipment and capable of being carried by personnel from one location to another.

3.43 Ground Fault Circuit Interrupter (GFCI): a device that functions to interrupt a circuit or portion of a circuit, within a predetermined time, when a current to ground exceeds a predetermined value that is less than that required to operate the overcurrent protective device of the supply circuit .

3.44 GFCI – Class A (personnel protection): a ground fault circuit interrupter that will interrupt the circuit to the load, within a predetermined time, when the ground fault current is 6 mA or more but not when the ground fault current is 4 mA or less.
(Refer to CEC Appendix B – Accepted SPE-1000 Field Approval Marks, for full definition)

3.45 Ground: a connection to earth obtained by a grounding conductor and a grounding electrode(s).

3.46 Grounded: connected effectively with the general mass of the earth through a grounding path of sufficiently low impedance and having an ampacity sufficient at all times, under the most severe conditions liable to arise in practice, to prevent any current in the grounding conductor from causing a harmful voltage to exist;
between the grounding conductors and neighbouring exposed conducting surfaces that are in good contact with the earth; or,
between the grounding conductors and neighbouring surfaces of the earth itself.

3.47 Grounded conductor (neutral or identified): One current carrying conductor of a service entrance, transformer or generator supply, intentionally bonded to the ground conductor at the power source to maintain a nominal voltage of 0 V to ground (equipotential).

3.48 Ground fault: an unintentional electrical path between a part operating normally at some potential to ground, and ground.

3.49 Ground Point: the point at which the system is connected to earth.

3.50 Ground-proving device: the device designed to verify system grounding.

3.51 Grounding: a permanent and continuous conductive path to the earth to establish equipotentiality.

*Note: The purpose of grounding any new system (transformer, generator or other alternate power source) is to establish an equipotential plane to eliminate step/touch potential.
In an existing building or urban environment, the equipotential plane has already been established since all existing power system/service and equipment should already be bonded together, and all system/service neutrals bonded to ground. In a rural or other non-urban setting, where there is no existing power system, grounding the power source establishes the only equipotential plane.*

3.52 Grounding Conductor: the conductor used to connect the service equipment, system, generator set or alternate power source to the grounding electrode(s)

3.53 Grounding Electrode(s): A buried metal water piping system or metal object or device buried in, or driven into, the ground to which a grounding conductor is electrically and mechanically connected. May be approved grounding rod(s) or grounding plate or an existing in-situ device acceptable to the AHJ. (AHJ)

3.54 HMI (Hydrargyrum medium-arc iodide lamp): AC arc metal-halide gas discharge medium arc-length lamp, made specifically for film and entertainment applications.

3.55 Head: nomenclature used to describe the portion of a luminaire assembly that contains the light source.

3.56 Inspection department — an organization legally authorized to enforce the CEC and having jurisdiction over specified territory.

3.57 Jumper: an electrical cable used from a distribution point to connect a load.

3.58 Jumper set: a set of single-pin jumpers used from a distribution point to connect downstream devices.

3.59 Live Performance: generic nomenclature used to describe the industry of the performing arts involving theatre, dance, opera and music.

3.60 Luminaire: a lighting instrument consisting of a light source, enclosure, electrical wiring and connector; and may include switches, reflectors, lenses, sockets, ballasts, supporting devices, and other apparatus for altering the quantity and quality of light emitted by the apparatus.

3.61 Multiple Connection Device: a single-pin splitting device with 1 line and 3 or more load connections per conductor, containing connections for a complete (3 phase-4 wire plus bond) set of grounded and ungrounded conductors of a system.

3.62 Overcurrent Device: any device capable of automatically opening an electric circuit, under both predetermined overload and short-circuit conditions, either by fusing of metal or by electromechanical means.

3.63 Overcurrent Protection: overcurrent device(s) used to protect electrical components, equipment, premises, and persons from hazardous current flow.

3.64 Personal Protection Equipment (PPE): any appropriate equipment worn or used by a worker in order to provide protection from local hazards of the job (e.g. gloves, safety and/or flash glasses, work boots, etc.).

3.65 Plug Connector: A plug connector (cord cap) is a connector, attached to a wire, cord, cable, chassis mount, having one or more exposed electrical blades, posts or pins, and constructed in such a way that it can be inserted snugly into a compatible socket connector to ensure a reliable physical and electrical connection. Plug connectors usually supply power to the load.

3.66 Power Source: see 3.67.

3.67 Power System (electrical): an electrical installation for electrical power distribution in which the energy provided by that installation to utilisation equipment is derived from a single energy source.

3.68 Qualified APS (Alternate Power Source) Operator: Certified person (C of Q holder) in charge of setting up, implementing and proving of grounding, mains distribution including requisite overcurrent protection, starting, balancing the load, monitoring during operation, and shutting down an Alternate Power Source. On film locations, the Operator is responsible for the layout, connection and monitoring of single-pin & sub-distribution networks for support equipment.

Note: Previously referred to as Generator Operator.

3.69 Qualified person: an individual who:

- a) is accredited by the appropriate jurisdiction to perform designated tasks; and,

- b) has the training, knowledge and developed skills necessary for safe and appropriate operation of the relevant equipment and installations; and,
- c) is trained to recognize and avoid any hazards involved.

3.70 Receptacle: one or more socket contact devices, on the same yoke or strap, installed at an outlet for the connection of one or more attachment plugs.

(Refer to CEC Diagram 1 and 2 for CSA configurations of receptacles)

3.70.1 Dual Circuit Fed Receptacle: a duplex receptacle, or two receptacles in the same box, fed from two separate sources. Utilised on sets for supplying line voltage and controlled (dimmed) voltage to the same device(s).

Note: check with AHJ for acceptance.



3.71 Set: A specific area utilised for any type of entertainment production. Typically including arenas, event or filming locations, sound stages or theatres.

3.72 Single-Pin: specifies single-pin locking connector (typically cam-type), generally with moulded polymeric, rubber or other composite insulator, commonly used for mains portable power distribution on stage, studio and location projects.

- a) generally approved for outdoor use; and,
- b) shall be colour coded to designate phasing; and,
- c) versions rated for 400 A; or,
- d) versions rated for 150 A; and,
- e) broadly refers to an entire method and system of distribution

(Refer to CEC Section 66)

(Refer to CSA 22.2-1691 - Single Pole Locking-Type Separable Connectors)

3.73 Socket Connector: A socket connector (receptacle) is a connector attached to a wire, cord, cable or chassis mounted, having one or more recessed electrical contacts designed to receive the corresponding blades, posts or pins of a compatible plug connector.

3.74 Strain Relief:

- a) a component or technique that protects electrical cables, wires, or connectors from damage caused by tension, pulling, or bending. Typically located at an entry or exit point on a piece of electrical equipment or luminaire and prevents any imposition of strain on the electrical connection(s); or,
- b) utilising industry standard methods such as a sling, choke, span set, tie line, or other non-permanent soft material of sufficient strength to adequately and safely, without damage to the cable, support the cable or cables to which it is attached to relieve any strain on electrical connection, or to support cables to flown systems.

3.75 Studio Connector (oval or round): A style of electrical connector employing low profile polymeric or rubber moulded insulation and 3 or 4 cylindrical pins, commonly used in the entertainment industry. The connector construction permits hard duty usage. Designed to be water resistant.

3.76 Switch: a device for making, breaking, or changing connection in a circuit.

3.76.1 General-use switch: a switch intended for use in general distribution and branch circuits and that is rated in amperes and is capable of interrupting its rated current at rated voltage.

3.76.2 Isolation switch: a switch intended for isolating either a circuit or some equipment from its source of supply and that is not intended either for establishing or interrupting the flow of current in any circuit.

3.77 Tap point: a connection point in an electrical system that does not interrupt current flow to other parts of the system.

3.78 Tee (electrical): Moulded single-pin device consisting of line and load connections, arranged in the form of a "T" to split or combine connections in the following configurations:

- a) Tapping Tee: one supply (line) connection to two load connections; or,
- b) Paralleling Tee: one load connection to two supply (line) connections.

3.79 Temporary: refers to anything that is not fixed to a facility and is portable in nature. It usually refers to equipment utilised on a specific production that has a limited run and will be removed when such production is completed or moved.

3.80 Tie-in: a hardwire (bare wire) connection to a panel, splitter, switch or switchboard of a power system.

3.81 Utilisation Equipment: any portable equipment loads that are connected on the power distribution system.

3.82 Utility Sources: the permanently installed electrical distribution systems of a building or structure that receive power directly from the local electrical utility.

3.83 Wet Location: a location in which liquids may drip, splash, or flow on or against electrical equipment.

4 General Practices

4.1 Permit

Those responsible for carrying out the work shall obtain a permit from the inspection department of the AHJ before commencing work with respect to set up, alteration, repair, or extension of any electrical equipment.

4.1.1 Permit/Notification of inspection

All productions and events shall obtain a permit from the inspection department prior to commencement of any electrical activity.

A copy of the permit shall be posted in a conspicuous place at the site and shall not be removed until the inspection is completed.

The permit shall be reasonably protected from environmental destruction.

4.2 Reporting of Serious Electrical Accidents or Incidents

Any serious electrical incident shall be reported as per the local AHJ requirements:

(AHJ)

- a) as soon as possible and not more than 48 hours after the occurrence; and,
- b) no person shall, except in the interests of public safety, saving life, relieving human suffering, continuity of service or preservation of property, interfere with or disturb any wreckage, article or thing at the scene of and connected with the occurrence, but in no case shall the wreckage, article or thing be carried away or destroyed by any person unless permission to do so is given by the AHJ.

4.3 Personnel

4.3.1 Qualifications

4.3.1.1 The person responsible for designing, implementing and monitoring any single-pin and single-pin based distribution system shall hold a valid Certificate of Qualification (C of Q).

4.3.1.2 Refer to definition for Qualified APS Operator.

4.3.1.3 Only a holder of a valid C of Q shall specify, design, create or dismantle any such system including any activity regarding or affecting the process of determining the nature or configuration of the relevant distribution system or network.

4.3.1.4 In theatre, event, and related industry sectors, the responsible person shall be a member of the lighting, audio or video department, certified as described above. In film and television, the responsible person shall be a member of the lighting department.

4.3.1.5 Single-pin systems:

- a) shall only be energized, and excepting emergency, de-energized, by certified personnel; and,
- b) only certified personnel as described above, or supervised registered apprentices, shall make any single-pin connections or disconnections, regardless of the system being de-energized; and,

- c) non-certified personnel shall be limited to carrying, depositing, and wrapping cable at the specific direction of the qualified person in charge.

4.3.1.6 For touring productions, where the designer of the electrical distribution system does not hold provincial qualifications and the set-up is done locally by technicians who may or may not hold provincial qualification, a duly qualified person is required to supervise and verify the set-up, at the direction of the designer or their representative. Only a locally qualified electrician may energize or de-energize the installation.

4.3.2 Personal Protective Equipment (PPE)

Electrical personnel shall wear appropriate PPE, all in good repair, relevant to the hazard level present, including:

- a) appropriately rated electro-resistive footwear displaying the Ohm symbol (Ω) and green triangle (Δ); and,
- b) gloves; and,
- c) safety glasses; and,
- d) face shield as applicable; and,
- e) rated clothing as applicable.

(Refer to the relevant Provincial or Territorial Occupational Health and Safety Act (OHSA), CSA Z462:21, Workplace Electrical Safety and CSA Z195:14 (R2023), Protective Footwear)

Note: Electrical PPE is crucial for safeguarding workers from hazards like electrical shock, arc flash, and burns. Specialized clothing, footwear, and accessories are designed to minimize exposure to these dangers. The specific PPE needed depends on the type and severity of electrical hazards present, including the voltage levels involved.

4.4 Equipment Approval

4.4.1 Electrical equipment used in all installations shall be approved and shall be of a kind or type and rating approved for the specific purpose for which it is to be employed. (CEC 2-024)

4.4.2 Approval Requirements for Electrical Equipment:

- a) the CEC recognizes Certification Bodies accredited by the Standards Council of Canada to approve electrical equipment (CEC Rule 2-024), including but not limited to CSA 22.2-300:18 (R2023) Portable Power Equipment; and,
- b) equipment shall be approved to the appropriate recognized standard to meet the requirements of the CEC; and,
- c) CE and UKCA marks are not recognized in Canada. (Refer to Appendix D – European Union and British Marks)

4.4.3 All electrical equipment shall be approved and bear an approval or certification mark acceptable to the local AHJ of;

- a) one of the accredited certification organizations; or,
 - b) field evaluation under SPE1000; and,
 - c) equipment not bearing a recognized certification or approval label or mark shall not be used.
- (Refer to Appendices A and B)

AHJ

4.4.4 Equipment components which are not part of a previously manufactured finished product, shall bear an approved component certification, which is not a certification or approval of any finished product or installation. (Refer to Appendix C - Component Certification Marks)

4.4.5 The use of all distribution and utilisation equipment shall conform to either:

- a) Sections 44 and 66 (amendatory/supplementary sections), plus all applicable (compulsory) sections of the CEC for theatrical shows; or
 - b) Section 66 (amendatory/supplementary section), plus all applicable (compulsory) sections of the CEC, for events and productions not specifically covered under Section 44 of the CEC.
- (Refer to applicable CEC compulsory sections.)

4.5 Operations

4.5.1 De-Energize Systems

4.5.1.1 During set-up or reconfiguration, the power supply to electrical installations, equipment or conductors shall be de-energized.

(Refer to 6.2.3.1 and CEC Rule 2-304)

4.5.1.2 When not in use or unsupervised, temporary power distribution systems shall be de-energized, locked out and tagged.

4.5.2 Structure Bonding

Scaffolds and other metallic structures used to support electrical equipment or power distribution shall be effectively bonded to ground.

(Refer to 6.1.1.3 and 6.1.1.5)

4.5.3 Elevated Installations

4.5.3.1 All overhead mounting of luminaires, projectors, electrical distribution, structural supports and other equipment shall be performed using hardware, equipment and safety factors consistent with safe practices and manufacturers specifications.

A secondary means of suspension (secondary safety device) shall be utilised with all such elevated equipment:

- a) the secondary safety device shall consist of an appropriately sized, non-meltable, non-combustible chain or wire rope adequate for the mass of the equipment; and,
- b) the secondary safety device shall be attached to an eye, loop, or other adequately sized and secured attachment point on the body of the suspended equipment, when available, and to the mounting or suspension system member or frame and should not primarily be fastened or attached to the yoke of the suspended equipment; and,
- c) accessories attached to equipment shall have separate, appropriately rated secondary safety devices; and,
- d) further information on overhead mounting of equipment of size and weight like that of stage and studio luminaires and mounted in a similar manner (e.g., with c-clamps, hook-clamps, or similar luminaire suspension hardware) can be found in ANSI Standard E1.53-20XX, OVERHEAD MOUNTING OF LUMINAIRES, LIGHTING ACCESSORIES, AND OTHER PORTABLE DEVICES: SPECIFICATION AND PRACTICE.

4.5.4 Followspot Positions

Followspot positions shall comply with ANSI Standards as follows:

- a) followspot positions in places of public assembly shall comply with the ANSI E1.28-2011, (R2021), Guidance on Planning Followspot Positions in Places of Public Assembly. E1.28 offers guidance on the planning of permanent followspot positions; or
- b) erected for Short-term Use in Entertainment Venues shall comply with the ANSI E1.66-2020, Safety Standard for Followspot Positions Erected for Short-term Use in Entertainment Venues. E1.66 covers the safety requirements for followspot positions in or on structures erected for short-term use, and positions not covered by ANSI E1.28.

4.5.5 Powerline Safety

Exercise awareness and operate safely around overhead powerlines while maintaining recommended limits of approach. Consult the local AHJ for information on powerline voltages.

Overhead distribution powerlines range from 120 volts to 50,000 volts; transmission lines range above 50,000 volts to 500,000 volts.

The use of equipment such as cranes, aerial lifts, boom trucks, scaffolds and ladders to perform tasks such as erecting or dismantling tents, assembling and dismantling of midway rides, stages, and raising antennae at remote locations creates electrical safety hazards when the equipment contacts or is in close proximity to the overhead powerlines. The equipment does not have to make direct contact with a powerline; electricity can jump or "arc" to the equipment thereby causing serious injury or electrocution.

Do not install metallic objects such as tent poles, midway rides and fencing adjacent to or under transmission lines as there will be an induced charge from the surrounding electric field.

There are specific clearance (Limits of Approach) requirements when operating near overhead powerlines. Example clearances are specified in Table below.

Nominal phase to phase voltage rating	Minimum Distance
750 or more volts, but no more than 150,000 volts	3m (10 ft)
more than 150,000 volts, but no more than 250,000 volts	4.5m (15 ft)
more than 250,000 volts	6m (20 ft)

Listed below are some steps to help alleviate injury or fatalities to workers:

- i) Look Up and Look Out - Locate all overhead powerlines and other electrical equipment prior to performing any work
- ii) Loading and unloading materials - dedicate an area away from all overhead powerlines to load or unload materials
- iii) Eliminate the hazard - install equipment away from the overhead powerlines. If this cannot be achieved, inform the local electrical utility or the owner of the powerlines that workers and high reach equipment will be working in the vicinity of overhead powerlines. Options may include temporarily disconnecting or relocating the overhead powerlines.
- iv) Document procedure - identify and inform ALL workers of the hazards around overhead powerlines.
- v) Inform - Post signs reminding the presence of overhead powerlines.
- vi) High reach equipment - Respect the limits of approach and keep all high reach equipment away from overhead powerlines.
- vii) Dedicated competent signaller - if required to work near the overhead powerlines, station a dedicated competent signaller within the view of the operator to warn the operator that any part of the high reach equipment or its load is approaching the limits of approach distances of the overhead powerlines.
- viii) Ladders - carry ALL ladders (including wood and fiberglass) horizontally.
- ix) Tents - Never place large tents near or directly underneath overhead powerlines.

4.5.6 Maintenance & Repair

4.4.6.1 A log shall be kept of all electrical maintenance or repair performed during any event, show or other production.

4.5.6.2 Any electrical equipment which has been maintained in the field shall be identified as having been repaired and carefully tested for safety and appropriate function before being re-used.

4.5.6.3 Equipment that has been repaired in the field shall have the details of the repair noted on the equipment so that the source supplier can verify that the repair has been properly completed and investigate and reapprove repaired equipment as necessary.

5 Power Sources

5.1 General

5.1.1 Types of Sources:

- Utility
- Internal Combustion Engine Driven Generator Sets
- Alternate Power Sources
- Storage Batteries

5.1.2 Common Low Voltages:

- 120 V single phase two wire

- 120/240 V single phase three wire
- 120/208 V three phase four wire "Y" (Wye)
- 240 V three phase three wire (Delta) – ungrounded system with ground fault indicating lights
- 240/416 V three phase four wire "Y"
- 277/480 V* three phase four wire "Y" (Wye)
- 347/600 V three phase four wire "Y" (Wye)
- 600 V three phase three wire Delta – ungrounded system with ground fault indicating lights

* Commonly on US manufactured equipment.

5.1.3 System Descriptors

- a) single phase two wire^{**}: One supply or line conductor, and one identified, grounded conductor (commonly called the neutral), plus a bonding conductor.
- b) single phase three wire^{**}: Two supply or line conductors, typically 180° apart electrically, and one common neutral conductor that is grounded and identified, plus a bonding conductor. (Also referred to as Centre Tapped)
- c) three phase four wire^{**}: Three supply or phase conductors, 120° apart electrically, and one common neutral conductor that is grounded and identified, plus a bonding conductor.
^{**} "PLUS BOND" is always assumed in the above standard terminology.
- d) three phase three wire: Three supply or phase conductors, 120° apart electrically, with no common neutral conductor. Requires ground fault indicator lights.

In portable power distribution, where the bonding wire is a specific conductor either in multiconductor portable cord, or a specific conductor run with any single-pin distribution system, the bonding conductor is counted; *therefore*:

- a) **single phase two wire** requires **three-conductor** portable cord.
- b) **single phase three wire** requires **four-conductor** portable cord, or **four wire** single-pin.
- c) **three phase four wire** requires **five-conductor** portable cord, or **five wire** single-pin.

5.2 Utility Sources

5.2.1 Fault Current Limiting

Systems employing single conductor cables, where the available fault current exceeds 10,000A (10kA), shall be supplied by means of current-limiting overcurrent devices to prevent inadvertent movement of the cables. (Refer to CEC, 66-452).

5.2.1.1 Fault Current Limiting shall be accomplished by:

- a) install a fusible disconnect within 3m of the source; and,
- b) the fusible disconnect shall incorporate current-limiting fuses; and,
- c) company switches or equivalent means of supply and connection for portable power systems shall be legibly and permanently labeled with their available fault current.

Fault Current means the electrical current that flows through a circuit during an electrical fault condition. A Fault Current occurs when one or more electrical conductors contact ground, a conductive surface that has continuity to the system, and/or each other. A Fault Current is several times larger in magnitude than the current that normally flows through a circuit and can be dangerous to both equipment and personnel.

5.2.2 Tie-ins

5.2.2.1 Tie-in connections to utility sources shall only be performed in accordance with CEC Rules 2-004, 2-006 and 2-012 and by either:

- a) a valid Construction and Maintenance C of Q holder and/or a licensed electrical contractor; or,
- b) where in an industrial establishment, the owner, an operator, or an employee holding the appropriate C of Q; or,
- c) a provincially certified individual where acceptable.

5.2.2.2 Where connections to existing utility distribution systems are made, the responsible person shall identify potential hazards created by any shutdown and notify the appropriate people including other users of the facility. That responsible person shall take suitable precautionary actions.

5.2.2.3 Conductors exiting a distribution panel shall be secured such that the weight of any cable does not put a strain on any electrical terminal or device. Such strain relieving shall be within 1m of the point at which the conductors exit the panel.

(Refer to CEC Rule 12-120 and to **Strain Relief** definition in this Standard.)

5.2.3 Overcurrent Protection

Conductors shall have overcurrent protection in accordance with Section 14 of the CEC.

5.2.4 Panel Covering and Labeling

Where temporary connections are made and the panel covers cannot be replaced, the panel shall be left in a dead front condition with temporary dielectric covering. The contact information of the C of Q holder and/or licensed electrical contractor and the event, production or show person responsible for the installation shall be clearly marked on any such temporary cover and the condition identified. If the panel is in an electrical room, all doors opening directly into the room shall be posted with the warning: **“Caution – Temporary Connections/Open Panels”**.

(Refer to CEC Rules 2-200 and 2-202).

5.2.5 Portable Transformers

5.2.5.1 When utilising a portable transformer,

- a) the transformer enclosure shall be bonded to the Xo point (secondary neutral) of the transformer with a conductor based on Table 16 of the CEC; and
- b) the transformer Xo point shall be bonded to the grounding connection of the transformer; and
- c) a grounding conductor, minimum size #4 AWG, is connected to an appropriate grounding electrode(s).

(Refer to CEC Sections 10 and 66).

5.2.5.2 The portable transformer grounding conductor shall

- a) be dedicated to the transformer; and
- b) be run directly, by the shortest practicable route; and
- c) have no more than two sets of mated, in-line, single-pin connections, excluding the connections at the grounding electrodes and the transformer; and
- d) not exceed 50 m in total length; and
- e) be not less than #4 AWG.

Note: the ground point shall be as close as possible to the transformer.

5.2.5.3 Portable transformers shall have secondary overcurrent protection rated or set at not more than 100% of the rated full load current as set out on the manufacturer’s rating plate.

5.2.5.4 Conductors to the secondary overcurrent protection shall have an ampacity of not less than 125% of the rated secondary current. Conductors after the secondary overcurrent protection shall have an ampacity of at least 100% of that protection.

(Refer to CEC 26-256 (2) and 14-100 and 14-104.)

5.3 Generator Sets and Alternate Power Sources

(all hereinafter referred to as “**APS**”)

5.3.1 Alternate Power Sources

- a) All APS installations involving single conductor cable and/or downstream overcurrent devices shall:
- b) be utilised in accordance with the CEC and this Standard; and
- c) be inspected by the AHJ; and
- d) have properly sized overcurrent protection on any ungrounded conductor; and,

AHJ

- e) be grounded.
(Refer to Section 14 and Section 66-200 of the CEC)

5.3.2 Qualified APS Operator

All APS sets shall be operated and maintained by a qualified operator as required by the relevant jurisdiction.

- a) While the APS set is running, the operator shall supervise the APS at all times. *One operator may oversee and control discrete generator sets if the generator sets:*
 - i) are directly accessible; and,
 - ii) are not separated by any roadway, waterway, obstructing structure or the like; and,
 - iii) are within direct line of sight and within a distance to meet the requirements of 5.3.2 (v) and (vi); and,
 - iv) can be satisfactorily and continuously monitored and controlled by the operator; and,
 - v) the operator has adequate safe control and oversight of the generator sets and of all immediate mains distribution and means of isolation; and,
 - vi) the operator is available to operate any emergency stop or isolation system, immediately without
 - vii) any delay
- b) Notwithstanding the above, *one operator may oversee and control no more than three paralleled generator sets provided that the paralleled generator sets:*
 - i) are directly accessible and are separated by no more than 5m; or,
 - ii) are mounted on the same platform or chassis; and,
 - iii) supply a common buss; and,
 - iv) *can be continuously monitored and controlled by the operator; and,*
 - v) the operator has adequate oversight of the generator sets and of all immediate mains distribution and means of isolation.
 - vi) the operator is available to operate any emergency stop or isolation system, immediately without
 - vii) any delay.

Note: similar requirements are applicable to alternate power sources

5.3.3 Mobile Generator (APS)

A mobile or vehicle mounted generator set that exceeds the rating of a (small) portable generator. (Refer to 5.3.4). Generally, supplies single conductor cable connections and shall be connected to a grounding electrode(s).

5.3.4 Portable Generator ($\leq 12\text{kW}$)

All (12kW and under) portable generators (Refer to **Portable Generators** definition in this Standard) shall be field verified to:

- a) be utilised in accordance with the CEC and this Standard; and,
- b) be rated at not more than 12 kW and 240 V; and,
- c) not be required to be connected to a grounding electrode if:
 - (i) the generator neutral is connected to the generator frame and marked "NEUTRAL BONDED TO FRAME"; and,
 - (ii) the generator supplies only multiconductor cord and plug connected equipment through receptacles mounted on the generator conforming to diagram 1 and 2 of the CEC (NEMA Standard); and,
 - (iii) the non-current-carrying conductive parts of the generator and associated equipment and the grounding terminals of the output receptacles are bonded to the frame of the portable generator assembly.

(Refer also to 6.2.2.1.)

5.3.5 Generator Set Labeling

Generator sets shall be clearly and prominently labeled, with such label on the control panel or other readily visible location, with the rating showing their respective prime power rating in kW and A/phase. This rating shall be based on the relationship of the alternator to the SAE net continuous mechanical kW (or bhp) of the prime mover.

5.3.6 Placement

APS sets placed on a street or location that is open to vehicular traffic shall have connections, panels, controls and any downstream distribution cable or devices situated on the side of the APS that is not exposed to that traffic.

5.3.7 Starting and Stopping

Generator sets shall only be started under a no-load condition (main circuit breaker(s) or field switch in the “OFF” position) and, unless under an emergency condition, stopped under a no-load condition.

5.3.8 Emergency Stop

APS sets shall have an emergency stop system, an accessible main circuit breaker, shunt trip or other emergency isolation means (refer to CEC Rule 28-900). The emergency stop system shall include means to simultaneously de-energize the ungrounded conductors by opening the overcurrent protective device or opening the main field of a generator alternator.

5.3.9 Cable Protection and Connections

5.3.9.1 APS sets with single-pin load connectors shall have:

- a) a minimum of one dedicated single-pin grounding connector; and,
- b) one single-pin bonding connector per 4 or 5 wire single-pin connection set; and,
- c) at least one additional system single-pin bonding connector.

(Refer to CSA Standard 22.2 NO. 300:18 (R2023) Portable Power Equipment)

5.3.10 Vehicle Installed APS Sets

5.3.10.1 APS sets installed in or on a vehicle shall provide single-pin or other appropriate main connections at an externally accessible panel.

5.3.10.2 For short duration installations, when it is not practicable to provide an externally accessible connection panel due to the short duration of the installation and not intended for permanent installation in the vehicle, cables shall exit over smoothly rounded, non-conducting material, with readily available securement points for strain relieving the cables.

5.3.11 Grounding

APS sets shall be grounded per Section 10 of the CEC.

- a) in-situ grounding shall be verified using an accepted ground-proving device; and,
- b) adhere to applicable ground-proving device manufacturer grounding specifications.

(Refer to 6.2.2)

5.3.12 Ground Fault Indication

Ground Fault detection systems providing visible and/or audible indicators, should be installed in prime power APS sets supplying single conductor distribution systems. Where ground fault detection systems are not installed, the operator should continuously monitor for ground faults.

6 Power Distribution

6.1 General

6.1.1 Bonding

- a) continuous bonding shall be provided throughout any electrical distribution system (Refer to CEC Rule 66-458); and,
- b) no downstream bonding of the neutral shall be used (the neutral shall only be bonded to ground at the system source); and,
- c) all non-current-carrying metallic parts of electrical equipment shall be bonded to ground.

6.1.1.1 Single Conductor Bonding Conductor Size

Ampacity of Overcurrent Protection	** Minimum Size of Copper Bonding Conductor - AWG
Up to 100	*4
Up to 400	2
401 and greater	2/0

Note: Sizes in this Table are industry standard and exceed the CEC Requirements.

** Also refer to CEC Section 66-200(3)(e).*

***Considers unknown increases in impedance due to possible connection degradation.*

6.1.1.2 Bonding Conductor

All distribution wiring shall include a bonding conductor.

- a) the bonding conductor shall be run with the line conductors in single conductor cable sets; or,
- b) the bonding conductor shall be an integral part of multiconductor cable.

6.1.1.3 Bonding of Conductive Surfaces

Any non-current-carrying conductive structures or surfaces having electrical wires passing through, on or over them shall be bonded.

6.1.1.4 Systems Bonding

Where more than one power system is used to supply any set, stage, tent, event or support equipment, or where more than one power system is used such that its distribution network or supplied load(s) come within 7.5m of any other such systems shall be bonded together.

6.1.1.5 Bonding of Supporting Equipment

All non-current-carrying conductive parts of any adjacent or supporting equipment that is near or in likely contact with the distribution system shall be bonded using acceptable bonding connectors (i.e., stages, scaffolding, lifts, fencing, etc.).

Note: All bonding connections shall be metal to metal to ensure a low impedance path. Remove paint and any rust or other oxides if such are present.

Not all connectors are acceptable in all jurisdictions.

(AHJ)

Refer to 4.5.2.

6.1.2 Power Supply to Vehicles

Connections to supply vehicles shall be situated in readily accessible boxes or compartments, on the curb side of the vehicle, and configured;

- a) with a smoothly bushed, non-conductive opening either independent of the access door; or,
- b) through the access door, with adequate provision to ensure that no metallic or sharp edges can contact the conductor(s); and if panel-mount connections
- c) not under the vehicle; and,
- d) not located in the area of trailer landing legs; and, if supply tails,
- e) with sufficient conductor length to allow the supply cord(s) to exit; and,
- f) with the resultant connection(s) adequately clear of the box or compartment, and not under the vehicle, and in any case, not less than 2 m in length; and,
- g) with provision for industry standard methods of attachment for strain relieving; and,
- h) strain relieved within 1 m of the connection point or point of entrance to or exit from the compartment or enclosure.

(Refer to 6.6)

Note: Refer to 6.2.5.5 re: panel mount connections

6.2 Single Conductor Distribution

6.2.1 Single Conductor Portable Power Feeder Cable:

Refer to ANSI E1.51, THE SELECTION, INSTALLATION, AND USE OF SINGLE-CONDUCTOR PORTABLE POWER FEEDER CABLE SYSTEMS FOR USE AT 600 VOLTS NOMINAL OR LESS FOR THE DISTRIBUTION OF ELECTRICAL ENERGY IN THE TELEVISION, FILM, LIVE PERFORMANCE AND EVENT INDUSTRIES IN CANADA for practices regarding single conductor portable power feeder cable systems usage.

6.2.2 Grounding

Excepting small portable generators, all separately derived (new) systems shall be grounded.
(Refer to CEC Section 10 and Section 66)

6.2.2.1 Grounding of “(Small) Portable Generators”.

Generators under 12kW that are frame grounded (neutral bonded to the machine frame) and identified as such and use only cord and plug connected loads conforming to Diagrams 1 and 2 of the CEC do not require connection to a grounding electrode subject to the provisions of CEC rule 10-214, including Appendix B of the CEC.

(Refer also to 5.3.4)

6.2.2.2 General Grounding Requirements

Any separately derived (new) system requires one or more grounding electrode(s), a copper grounding conductor and approved connectors.

*All grounding electrode connections shall be **verified** and shall be acceptable to local Authorities Having*

AHJ

Jurisdiction.

6.2.2.3 Grounding Electrodes:

- a) two 3m (10') grounding rods spaced 3m (10') apart **driven to full depth** *; or,
- b) one approved grounding plate (hot-dipped galvanized if ferrous), minimum 0.186m² (2 ft²) area (typical 250mm (10") x 406mm (16") x 6.4mm (¼")), buried a minimum 600mm (2') deep *; or,
- c) a buried metal water piping system, e.g.: fire hydrant ** or water faucet, providing the water faucet is connected to a grounded conductive metallic piping system of sufficient conductive capacity; or,
- d) an existing metal object of equivalent size and depth to a) or b) above.
(Refer to Standard CSA 22.2 NO. 41:22, Grounding and Bonding Equipment); and,
- e) the grounding electrode shall be as close as possible to the power source.

The AHJ may prefer grounding plates over grounding rods in urban settings; in-situ (i.e.: existing) ground connection points may also be preferred. Check with AHJ for fire hydrant connection access.**

(Refer to CEC rule 10-102 Grounding Electrodes)

AHJ

6.2.2.4 Utility Locates

A utility locate shall be performed prior to installing grounding rods. This includes public and private areas.
(Locates will not include private utilities)

Call before you dig. Make sure all underground services are located before installing grounding electrodes.

6.2.2.5 Grounding Conductor:

- a) a grounding conductor shall be run directly, by the shortest practicable route, with a maximum length of 50m between the grounding electrode and the power source grounding connection terminal, using a dedicated grounding conductor with not more than 2 in-line single-pin connections; and,
(Refer to CEC rule 66-200(2))
- b) this conductor shall NOT be tapped (teed) into any circuit bonding conductor; and,
- c) this conductor shall be minimum #4 AWG.

6.2.2.6 Ground Verification/Proving

All grounding electrode connections shall be verified with a ground-proving device. Follow all device operating instructions or contact the device manufacturer.

6.2.2.7 APS to Structure Grounding/Bonding

When an additional power source such as an APS is supplying power to equipment utilised in a utility supplied building or structure, the APS(s) shall be either grounded to the building electrode or to the separate APS grounding electrode(s). The building and the separate grounding electrode(s) shall be bonded together in accordance with Section 10 of the CEC. Acceptable methods of connecting to the building grounding electrode(s) shall be by connection to the effectively grounded structural metal members of the building structure. The conductor for the grounding jumper shall be minimum #4 AWG.

Note: When different electrical systems are in proximity to each other and do not share the same grounding electrode they shall be bonded together. (Refer to 6.1.1.4)

AHJ

6.2.2.8 APS Hydrant Grounding

For an event of a temporary nature in urban areas, grounding an APS set to a fire hydrant using a threaded connecting device is acceptable under the following conditions:

AHJ

- a) the installer obtains approval from municipal owners and the local Fire Department to attach to the hydrant; and,
- b) it is not possible to install or use a grounding electrode as specified by CEC Rule 10-102; and,
- c) proof of ground resistance is verified by an accepted ground-proving device and confirmed with the local AHJ; and,
- d) the connection device is made of copper, bronze or brass.

Fire hydrant grounding device



Refer to requirements of CSA C22.2 NO. 41:22 (Grounding and Bonding Equipment)

6.2.3 General Practices

6.2.3.1 No work is to be performed on any energized (live) electrical system (Refer to CEC Rule 2-304). Connection and disconnection of any single-pin locking type connector, including cam-type, or single-pin non-locking connector, to or from any part of an energized system, is working live.

6.2.3.2 Single-pin and single-pin based distribution systems, stage and studio lighting and/or power distribution systems:

- a) shall only be energized when the responsible certificate holder, or designee of equivalent certification as determined by the responsible provincial or territorial body, is present; or,
- b) may be energized without a responsible certificate holder or designee present when:
 - i) utilised exclusively to supply a panelboard or grouped set of panelboards for the purpose of power distribution to shop tools and similar equipment; and,
 - ii) without any additional down stream single conductor cables; and,
 - iii) not connected to any supply that simultaneously energizes stage and studio lighting and/or machinery.

6.2.4 Single Conductor Cables

Single-conductor cables shall be:

- a) permitted in sizes No. 4 AWG and larger; and,

- b) a matched set with the same length for all conductors of the circuit, including the bonding conductor; and,
- c) rated for the circuit voltage and suitable for the intended application, such as Type PPC/SC.

*Note: Welding cable shall not be permitted for this use. Welding cables are only intended for use with electric welders having an open circuit secondary voltage of 100 V or less.
(Refer to CEC Table D1)*

6.2.5 Connections

6.2.5.1 Single pin connectors (cam-type) are identified in the CEC as locking type connectors.
(Refer to CSA C22.2 No. 1691:21, Single Pole Locking-Type Separable Connectors)

6.2.5.2 Where single-pin connectors are used, they shall have the socket connector attached to the load end of the line/phase conductor (CEC Rule 66-400(3)). It is permitted that the neutral and/or the bonding conductor have the plug connectors attached to the load end of the cord. (CEC Rule 66-400(4)).

6.2.5.3 Cam-type single-pin connections shall be FULLY engaged (FULLY rotated) to ensure a solid electrical connection which can operate to its rated ampacity.
(Refer to Appendix H – Correct Mating of Cam-type Single-Pin Connectors.)

6.2.5.4 Misapplication of Cam-Type Single Pin Connectors

Standard (ball-nose) series and J series (taper-nose) cam-type single-pin locking connectors shall not be interconnected.

- a) any interconnection between two different series of connectors shall be accomplished using an approved adapter; and,
- b) rigid adapters shall not be used for direct connection to any panel-mounted connector or other fixed device.

Direct interconnection of the different series is a misapplication of the devices, which:

- a) voids any weatherproof type rating; and,
- b) voids their electrical approval.

(Refer to CEC Rule 2-034)

Note: Use as described without an approved and appropriate adapter is an unsafe practice, and any liability for an improper connection rests with the user.

6.2.5.5 Panel or chassis mount single-pin connectors shall:

- a) if situated on the exterior of a mobile APS or other vehicle, be installed within an appropriately rated enclosure, as per CEC Rule 2-400, such that when not in use or while traveling, the connectors cannot be exposed to rain, snow, slush, road salt or contaminants; and,
- b) be installed from the inside of enclosures, with attaching fasteners adequately clear of any possible contact with terminals or busses. *Note: Essential on any APS or vehicular application to prevent pull-out from excessive mechanical force.*

6.2.5.6 Single-pin connections shall be made in the following order, *with the circuit de-energized*:

- connect the bond (green)
- connect the neutral (white)
- connect the phases or lines (red, black, blue; or L1, L2 [red, black])

Connections shall be made working from the load end of the system to the supply. The last connection shall be to the power source, with the downstream system completed.

6.2.5.7 Single-pin disconnections shall be done in the following order, *with the circuit de-energized*:

- disconnect the phases or lines (red, black, blue; or L1, L2 [red, black])
- disconnect the neutral (white)
- disconnect the bond (green)

6.2.5.8 Any unused single-pin connector that is part of a circuit shall be sealed or capped with a seal or cap that is manufactured for the purpose.

Unconnected single conductor cables that are part of a bundle or run with unbundled cables shall be capped at any exposed end to avoid contact with any induced voltage.

e.g. any unused conductor on a 5 wire set feeding a single phase load.
(Refer to CEC Rule 66-456(2(d)))

6.2.6 Overcurrent Protection and Isolation

6.2.6.1 Single conductor cables shall have overcurrent protection not exceeding the ratings set out in Table 1.

6.2.6.2 Overcurrent protection shall be employed for any single conductor phase or line portable power cable.

- a) Overcurrent protection employing 100% rated circuit breakers shall have clearly visible permanent labeling identifying the 100% rating of the device; and,
- b) Adjustable circuit breaker assemblies shall be clearly labeled with their adjusted setting.

(Refer to Table 1) (Refer also to CEC Table 12A and Tables 5A, 5B, and 5C as applicable)

6.2.6.3 "Tap" points used in a single conductor power distribution system, which go from a higher ampacity conductor set to a lower ampacity conductor set and extend beyond 3 m in total length (distance being calculated from the tap point to the downstream device bus), shall have an appropriately sized overcurrent protection at the tap point.

6.2.6.4 Single conductor jumper sets, of no less than # 2 AWG – PPC, may be utilised to facilitate the connection of distribution devices to the tap point, without the addition of overcurrent protection, providing that their length, combined with any supply tail or lead on the downstream device, does not exceed the 3m. total, as described above. This shall not be interpreted to include any type of adaptor but shall be limited solely to single-pin connectors.

(Refer to CEC Section 66)

6.2.6.5 When connecting to a power source, a means of isolation and suitable overcurrent protection, either internal or external to the source panel, shall be used between the power source and the "on-set" distribution:

- a) in a location readily accessible to the "set", a control device capable of safely establishing and interrupting the "on-set" distribution loads either directly or by remote control (CEC definitions & CEC Rule 14-406); and,
- b) any control device used in combination with an overcurrent device shall be connected so that the overcurrent device is dead when the control device is open (CEC Rule 14-404).

(Refer to CEC Section 14).

6.2.6.6 Feeder cables that are supplied from a limited access location such as a locked electrical room shall be provided with the following:

- a) a lockable disconnecting means that is readily accessible, outside of and within 5m of the limited access location; and,
- b) any line side connectors between the limited access location and the lockable disconnecting means shall be secured.

Note: This requirement typically relates to use of repurposed industrial spaces.

6.2.6.7 Mutual heating practices for single conductor cables.

- a) single conductor cables in close proximity to one another shall be rated for ampacity as multiconductor cables.

(Refer to CEC Section 4 & Rule 66-454(1)).

- b) bundled single conductor cables of any one circuit shall be permitted to be free air rated, without correction factors, provided different circuits are kept a minimum of a bundle diameter apart.

(Refer to CEC Rule 66-454(2)).

6.2.6.8 Any single conductor feeder circuit branch shall have a minimum of one additional isolation switch installed for any expansion of the system.

(Prevents working on energized systems per CEC Section 0 - Object and Rule 2-304(1))

6.2.7 Colour Coding

6.2.7.1 Connector Colour Coding

Connectors for single-pin distribution systems shall be provided with standard colour coding which shall be accomplished by:

- a) manufactured coloured connectors; or,
- b) connectors that are tape coloured for their entire length except for 30mm from the mating end; and,
- c) length colour coding shall not use the colour codes required in 6.2.7.3 and 6.2.7.4.

(Where single conductor cables (not already identified with coloured connectors) are used, the colour codes required in 6.2.7.3 and 6.2.7.4 shall be applied with coloured PVC electrical isolating (phasing) tape at both ends of each cable, commencing 30mm from the mating end of the connector. Taping is to be completed before the cables are connected.)

6.2.7.2 General Circuit Identification

Circuits shall be identified with:

- a) any phase colour for 2-wire phase to neutral circuits; and,
- b) any two phase-colours for single phase circuits on single or 3 phase systems; and,
- c) any two phase-colours for phase to phase individual loads

6.2.7.3 Systems at or Less Than 150V to Ground

Standard colour coding shall be:

- a) Red, Black, Blue, *Line or Phase*
- b) White *Neutral (identified conductor)*
- c) Green *Ground or Bond*

6.2.7.4 Systems Above 150V to Ground

Standard colour coding shall be:

- a) Orange, Brown, Yellow *Line or Phase: permitted only on systems operating at these voltages*
- b) White *Neutral (if used), (identified conductor)*
- c) Green *Ground or Bond*

6.2.8 Special Practices for Systems Above 150V to Ground

(Refer to Appendix K - Single-Pin Connectors Utilised at Greater Than 150 Volts to Ground)

6.2.8.1 In-line single-conductor cable connections forming part of a circuit of more than 150 volts to ground shall:

- a) be coloured as required in 6.2.7.4; and,
- b) be mechanically protected by enclosing the connectors(s) in a lockable, non-conductive box or similar enclosure; and,
- c) be clearly identified with a label that is;
 - i) securely attached to each connector or connection point; and
 - ii) resistant to damage from the environment in which it is placed; and,
- d) elevated a minimum of 150mm (6") per 6.4.7.2(c).

Electrical distribution on single-pin connectors at voltage(s) above 150 volts to ground (Nominally 250 volts phase to phase) may be present in sectors of the entertainment industry utilising exhibition spaces, industrial buildings and/or portable equipment at studios and other locations. Existing, temporary, or portably installed single-pin distribution circuits of 416, 480, or 600 volts might not be identified or quarantined (physically isolated in a lockable enclosure).

6.2.8.2 The lockable enclosure shall:

- a) be labeled on the outside, in a conspicuous, legible, and permanent manner, identifying the supply voltage of the circuit; and

- b) be acceptable to the AHJ.
(Refer to CEC 66-456(4), 66-456(7) and 66-456(8))

Note 1: Lockable (locking) means that a tool or key is required to access the enclosed connections (example: zip ties).

Note 2: Enclosures shall incorporate sufficient drainage holes to prevent any accumulation of water.

6.2.9 Single Phase Three Wire System Connections

Where any three phase distribution equipment is supplied from a single phase three wire system the following shall apply:

Any single phase power supply shall have its load connectors connected:

- a) bond to bond direct connection only; and,
- b) neutral to neutral direct connection only; and,
- c) phase to line (Phase A to Line 1, Phase B to Line 2), direct connection only; and,
- d) any remaining Phase "C" or third line from the load shall be capped off.

(Refer to Appendix G - The Use of Three Phase Distribution Equipment on Single Phase Three Wire Sources)

6.2.10 Voltage Drop

6.2.10.1 Voltage drop on single conductor feeder cables shall not exceed 3%; by,

- a) limiting the length of the cable; or,
- b) increasing the conductor size of the cable; or,
- c) if using 4/0, paralleling the cables.

Distance from power source to distribution point for 3% voltage drop @120V – in metres (feet)

Current (Amps)	Copper conductor size, AWG				
	#4	#2	1/0	2/0	4/0
	Cable length in metres (feet)				
50	37.5 (123)	59.4 (195)	94.5 (310)	119.4 (392)	189.6 (622)
100	18.6 (61)	29.7 (97)	47.4 (156)	59.7 (196)	94.8 (311)
125	15 (49)	23.7 (78)	37.8 (124)	47.7 (156)	75.9 (249)
150		20.1 (66)	32 (105)	39.6 (130)	64 (210)
175		17 (56)	27.4 (90)	34 (112)	54.8 (180)
200			23.7 (78)	29.7 (97)	47.4 (156)
250				24 (79)	37.8 (124)
300					32 (105)
350					27.4 (90)
400					23.7 (78)

6.2.10.2 Voltage drop calculations shall be applied based solely on the rating of the immediate upstream overcurrent protection.

6.2.11 Circuit Tapping

6.2.11.1 Rigid devices such as tapping or paralleling tees, rigid three-fers, rigid adaptors or turnarounds and the like shall:

- a) not be directly connected to any single-pin plug or connector rigidly housed or mounted in a multiple connection device; and,
- b) not be directly connected to a panel mount inlet or outlet or to a multiple connection device with a cable less than 2m in length; and,
- c) be arranged so that no mechanical strain is imposed on the connection.

6.2.11.2 More than one tapping or parallel tee per conductor may be used at any one point in a power distribution system, providing that each connection is;

- a) fully engaged; and,
- b) strain relieved such that there is no mechanical strain on the electrical connection. (Refer to CEC Rule 66-456 (6) (c)); and,
- c) where possible, any distribution splitting or combining devices requiring more than two load connections per conductor should use a single approved multiple connection device at that point.

6.3 Multiconductor Distribution

6.3.1 Multiconductor Cable Connectors:

- a) any multiconductor cable shall be terminated in an approved multipole plug or socket connector; and,
- b) oval moulded 3-pin studio connectors shall be used only for 120V circuits; and,
- c) moulded studio socket connectors, either on cordsets or in any form of distribution equipment, shall not utilise connectors employing inserted rejection rings; and,
- d) moulded studio connectors and stage pin connectors are not rated for connection or disconnection under load, and any unconnected device shall remain unenergized; and,
- e) all multicable utilising 19 pin circular connectors for lighting purposes all multicable utilising 19 pin circular connectors shall conform to Table 2A and ANSI E1.80; and,
- f) in-line single-pin connectors shall only be used on approved single conductor cables as per Table 11 and Section 66 of the CEC; and,
- g) the individual inner-conductor insulation of multiconductor cable should only be exposed within a rated multi-pole connector or enclosure and is not rated or approved to be exposed to abrasion, moisture, strain or U.V.; and,
- h) only electrical equipment approved for the application should be used under the provisions of this Standard and the CEC.

Note 1: Studio and stage pin connectors all display a version of the limitation prohibiting connection or disconnection under load.

Note 2: Stage pin connectors which are not certified for use in Canada shall not be utilised.

Note 3: Removal of the exterior jacket and installation of single-pin connectors onto the exposed inner conductors exposes interior construction of the multiconductor cable to the ingress of moisture and attendant contaminants. Unprotected inner-conductor insulation exposed to environmental conditions leads to degradation of the conductor insulation resulting in insulation cracks and tears, exposing "live" conductors, which is unsafe and contravenes Section 2-024(1) of the CEC.

*** See following illustration*

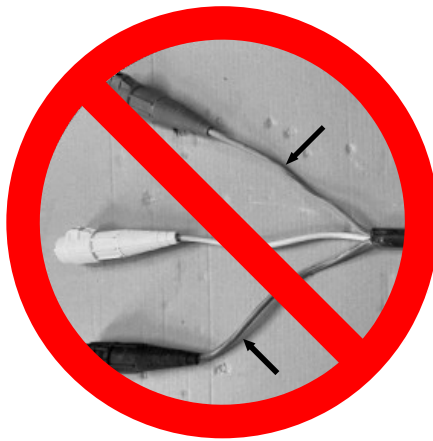

Misapplication of Single-pin Connectors on Multiconductor Cables

6.3.2 Multiconductor Cable With 19 Pin Circular Connectors

6.3.2.1 Multiconductor cables with 19 pin circular connectors with locking ring utilising 12AWG/14C (12AWG/19C) (operating at not more than 150 V to ground), when connected to non-dimmed distribution, shall have overcurrent protection not exceeding 15 A.

(Refer to CEC Rule 4-012 and Table 2 for six circuit 120V pinouts [120V ANSI E1.80, Pinout Configuration Types for Special-Purpose Multi-circuit Cable Systems type U] and refer to Table 2A for all nominal 220V pinouts [19 Pin Circular Connector Designations TABLE 1 and TABLE 2 from ANSI E1.80]).

6.3.2.2 Where the non-dimmed distribution has 20 A overcurrent protection, cable assemblies as described above shall have a maximum of three of their six circuits energized when using 2 kW loads. The remaining circuits shall remain unenergized with their respective overcurrent protection set in the open position. (Refer to CEC Rule 4-012).

6.3.2.3 Multi-circuit break-ins and break-outs, utilising 19 pin circular connectors and specific to the applied voltage and configuration, shall be clearly labeled per Tables 2 and 2A. The relevant configuration is determined by the supply end hardwired connector or break-in. (Refer to end of Table 2A for examples)

Note: Mating of incompatible pinout configurations can create an electrical hazard with detrimental consequences for personnel and equipment.

6.3.2.4 Multiconductor cables with 19 pin circular connectors with locking ring, devices and systems that are used in configurations other than those identified in Table 2 shall have their purpose and operating voltage clearly marked at each end of every cable comprising that run.

(Refer to Table 2A and ANSI E1.80)

6.3.2.5 Multiconductor cables with 19 pin circular connectors with locking ring utilising 16AWG/19C shall only be used:

- a) with circuits not exceeding 10 A; and
 - b) in conjunction with dimming apparatus; and
 - c) with Pin Designations per Tables 2 and 2A; and
 - d) not used for any system supplying power directly from distribution equipment
- (Refer to CEC Rule 4-012)

6.4 Distribution Equipment

6.4.1 Cable Types

Cables shall be of types specified in CEC Table 11 for the specific conditions of use and shall be suitable for the location involved.

(Refer to CEC Rule 12-406)

6.4.2 Cordset Connection Practice

- a) Cordset connectors shall be fully engaged; and,
- b) to prevent damage to cord entry to connectors, cordset connections shall not be knotted.

6.4.3 Allowable Cordset Ampacities

The allowable ampacity of flexible insulated (multiconductor) copper cord commonly employed in the industry is contained in Appendix E (Allowable Ampacity of Flexible Insulated [Multiconductor] Copper Cord).

6.4.4 Overcurrent Protection

Any cable, cordset, adaptor or distribution box shall have appropriate upstream overcurrent protection. █

6.4.5 Distribution Boxes

All distribution boxes shall be labeled as to the rated voltage, current and the CSA type, per Table 65 of the CEC.

6.4.5.1 All distribution boxes shall be labeled as to the rated voltage, current and the CSA type, per Table 65 of the CEC.

6.4.5.2 No distribution box shall be employed in any manner such that its socket connectors face upwards.

6.4.5.3 Cordsets with single or multiple gang devices utilising 5-15R or 5-20R receptacles may be employed with their connectors facing upwards, for use only in dry locations.

6.4.6 GFCI's

Class A GFCI's shall be used on circuits supplying all utilisation equipment such as, but not limited to, audio racks, luminaires, kitchen units, porta-potties, portable and stationary power tools and wash stations:

- a) in wet or damp locations as defined above, per CEC, and in areas of high humidity; and
- b) when within 3 m of standing water such as pools, hot tubs, or any other artificially created body of water, or of conductive liquids; and
- c) when snow, salt, or slush is or is likely to be present; and
- d) as required by the CEC.

The GFCI device, as required by the CEC:

- a) shall not be located within 3 m of any water or conductive liquid; and
- b) shall be in a type 3R, type 4 or type 6 enclosure elevated a minimum of 100 mm. above the ground, with connections rated for wet location; or
- c) shall be mounted in an elevated weatherproof cabinet or box, constructed on site for mounting and protection of distribution equipment.

GFCI devices shall be tested according to manufacturer's instructions prior to use, **each time** the unit is energized.

GFCI devices **shall not be utilised**:

- a) in circuits supplying exit lighting; or
- b) in circuits supplying fire, smoke, or carbon monoxide detection and alarm systems; or
- c) in circuits supplying fire pumps; or
- d) in circuits where tripping of the GFCI may result in injury.

Receptacles having CSA configuration 5-15R or 5-20R installed in amusement parks, midways, carnivals, fairs, festivals, activity in tents and similar events, where readily accessible to the public and intended to supply loads in outdoor or damp locations shall be protected by ground fault circuit interrupters of the Class A type.

(Refer to CEC 66-404)

6.4.7 Wet Locations

6.4.7.1 All cable connections shall be kept clear of water or wet surfaces by use of appropriate elevation, but no less than 100 mm (4").

6.4.7.2 Distribution boxes shall be used in accordance with the requirements of their respective rating types with covers securely closed. When used outdoors or subjected to water, usage shall be as follows:

- a) no distribution box shall be placed in standing water or in a location likely to collect water in conditions of heavy rain or flooding; and,
- b) Type 1 boxes, and boxes with installed non-waterproof devices, shall be covered to prevent intrusion of water, snow, sleet or slush; and,
- c) all boxes should be elevated a minimum of 150 mm (6"), or greater, as needed to prevent possible immersion of the box; and,
- d) outdoor use boxes shall be employed such that they will repel water as designed; and,
- e) installed such that no line or load connectors face up in any manner that allows collection of water or any liquid; and,
- f) boxes and enclosures designed and manufactured for permanent installation shall not be used for portable applications.

6.4.8 Luminaire Overcurrent Protection

(Refer to CEC sections 14 & 44)

6.4.8.1 All luminaires shall be connected to a circuit having overcurrent protection from dimming, distribution boxes or other control equipment.

6.4.8.2 Any luminaire on single conductor feeder shall have appropriate individual overcurrent protection.

6.4.9 Dual Circuit Fed Receptacles

(AHJ)

Where accepted by the local AHJ, Dual Circuit Fed Receptacles, (refer to Receptacle definition in this Standard) may be utilised on film, television, theatre or similar sets using only the following procedure, and using approved Section 12 wiring methods:

- a) the two systems shall incorporate a bonding conductor from their respective supply points; and,
- b) the two system grounding conductors shall be bonded together; and,
- c) the bonding conductors from both systems shall be attached to the bonding screw(s) in the device box; and,
- d) the bridging tabs from both sides of the receptacle shall be fully removed; and,
- e) the (top) half of the receptacle shall be supplied with direct line voltage from the non-dimmed distribution system; and,
- f) the other half (bottom) shall be supplied from a remotely controlled dimmed source; and,
- g) the approved warning label shall be installed, such that the device mounting screws also capture the label; and
- h) the warning label material shall be Nomex™ or non flammable equivalent; and
- i) for the purpose of controlled isolation, immediately adjacent and within sight of the dual-fed device box, (Refer to CEC Rule 14-414) one of the following methods shall be used:
 - i) the supply feeds for the device shall be limited to 30 cm (twelve inches) of portable cord protruding from the device box, with plug connectors attached and labeled with the appropriate information; or,
 - ii) the dual-fed device box shall be supplied from a lockable 4 - pole isolation switch, rated at not less than 20 A, installed directly adjacent to the dual-fed device, and connected with hard wire connections and installed in a metallic raceway.

(Refer to Appendix F - Dual Circuit Fed Receptacle, for connection diagram and label detail)

Attachment of the cover plate will cover the label, without in any way disturbing its securely fastened nature.

This is critical, so that any subsequent removal of the cover plate reveals the warning label, indicating the unusual and potentially dangerous condition of more than one source of supply, per CEC Rule 14-414.

6.4.10 Adaptors

- a) shall only be used where it is necessary to convert configurations between connectors of the same rating; or,
- b) where, for the purposes of temporary convenience, a plug (attachment cap) of lesser rating is supplied from an appropriately protected circuit, to supply a differing configuration (connector body) of a higher rating.

Example: A 60 A socket connector such as a 3-Pin studio connector may be connected to a 15 A supply with a 15 A plug connector (cord cap).

6.4.11 Twofers (Y-cords)

- a) twofers shall have only one plug connector; and,
- b) reverse twofers, which are units incorporating more than one plug connector to a single socket connector shall not be employed; and,
- c) twofers shall be approved assemblies consisting of plug connectors and socket connectors consistent with the supply circuit ampacity.

(Refer to Appendix J – Twofers (Y Cords))

6.4.12 Power Bars

Power bars shall:

- a) be plugged directly into an overcurrent protected receptacle; and,
- b) not be daisy-chained from another power bar; and,
- c) not have a coiled or looped cord when in use; and,
- d) be protected from physical damage; and,
- e) not be used in wet or damp locations; and,
- f) be used with caution if supplied from a 20 A circuit.

6.5 Cable Protection

6.5.1 All cables shall be protected from mechanical damage. Cables subject to vehicular or extensive personnel traffic shall be protected in an appropriate manner. In high traffic areas, cable shall be laid in cable protectors (mats, ramps, troughs) or suspended.

CEC rule 2-200 requires electrical equipment be guarded so that adequate provision is made for the safety of persons and property. Route cables such that:

- a) they are appropriately protected or located so that they are not subject to mechanical damage from doors, vehicles, other mobile equipment or animals; and,
- b) they are not a trip hazard for personnel.

(Refer to CEC Rule 66-450(c)).

Cable protection shall comply with the Accessible Canada Act or respective provincial legislation.

6.5.2 Flexible cords and portable power cables are not rated for direct burial. Consult the local AHJ for alternatives.

AHJ

6.5.3 Where it is necessary to run cables through doorways, positive protection shall be provided in the form of a substitute doorframe or portion of doorframe that allows door closing, with appropriately bushed or smoothly rounded non-conductive passage for the cables.

(Refer to CEC Rule 12-402(3) and Appendix L Doorway Insert and also to 6.5.1)

Note: Prevents fire and smoke propagation.

6.6 Cable Strain Relief

(Refer to **Strain Relief** definition in this Standard)

6.6.1 All connections to elevated panel mounted (rigid) connectors on sets, company panels, generator sets, alternate power sources, trucks, trailers and similar equipment shall be adequately strain relieved. Such cables shall be strain relieved within 1m of any connection point.

6.6.2 Any connection in a vertical cable run shall be strain relieved such that there is no mechanical strain on any connection. Connectors shall not be knotted to accomplish strain relieving.

6.6.3 Vertical cable runs shall be adequately strain relieved within 1m of the fall point and every 15m thereafter. Cable pickups shall be made in such a way to avoid lateral movement of any pipe, truss, scaffold or other structure.

6.6.4 Cable pickups for multiple runs of multiconductor cables shall pick up no more than 4 (four) cables in each individual wrap or choke point.

7 Utilisation

7.1 Location of Utilisation Equipment

Utilisation equipment shall only be used in locations for which it is approved, unless suitable precautions are taken to protect it from inclement weather or from effects using water or other liquid.

(Refer to CEC Rule 66-402(5) and 6.4.7 of this Standard)

(Refer also to ANSI standard E1.58-2017 - Electrical Safety Standard for Portable Stage and Studio Equipment Used Outdoors).

7.2 Luminaires

All luminaires shall be approved to Canadian standards and bear a certification mark from a recognized testing laboratory or an approval label to the Model Code for the Field Evaluation of Electrical Equipment (SPE-1000).

7.2.1 Set Practical

A working "On - Set" luminaire may be standard or custom and receives its power from the portable distribution system. Unless it is an approved two wire fixture, it shall be bonded to ground. If installed on a set piece, it shall be attached and connected with CEC Section 12 wiring methods excepting where Section 44 is applicable (Rule 44-350).

7.2.2 LED Systems

LED systems shall be implemented in compliance with the requirements of the Canadian Electrical Code (CEC Part 1), the respective Provincial Electrical Code, and the manufacturer's specifications.

Installations shall:

- a) use approved components; and,
- b) not rely on component approval only; and,
- c) have the completed system inspected and approved; and,
- d) ensure ampacity rating of conductors including allowance for voltage drop.

7.2.3 Emergency Lighting

Emergency lighting and exit signs shall be provided and utilised where none is present or functioning, and to augment the installation, as required by local building and fire codes.

Installation of emergency lighting shall conform to Section 46 of the CEC.

7.2.4 Discharge Luminaires

7.2.4.1 All personnel shall be made aware of high voltages used by gas discharge lamps such as CSI, fluorescent, HMI, neon and xenon. Users of luminaires with these light sources shall:

- a) be familiar with the ballasts used; and,
- b) ensure that all safety devices are in proper working order.

7.2.4.2 Prior to "striking" an HMI, xenon or similar discharge lighting source, the operator shall make sure that no one is in contact with the unit, any support, or the ballast, due to stray ignitor-created high voltage arcing.

7.2.4.3 In damp or wet conditions, while "striking" these luminaires, all personnel shall be clear of these or any similar discharge lamp head.

Note: Humid conditions increase the conductivity of the air and thus the likelihood of arcing.

7.2.4.4 Advise all personnel that HMI, xenon or similar discharge lighting sources emit ultraviolet (UV) light. Follow appropriate practices and manufacturer's recommendations. Never view an ignited discharge lamp directly.

7.3 Luminaire Handling

7.3.1 Hot luminaires shall be allowed to cool sufficiently before moving. Appropriate PPE shall be worn when handling hot luminaires.

7.3.2 Before a luminaire is re-lamped or otherwise worked on, the luminaire shall be switched off, allowed to cool and disconnected or isolated from the power source. Implement lock-out/tag-out procedures where appropriate.

7.3.3 When replacing lamps, utilise appropriate PPE and follow the manufacturer's recommendations.

7.3.4 Any open-faced luminaire shall have protection in accordance with CSA standards covering such equipment, including but not limited to CSA C22.2 NO.166 Stage and Studio Luminaires, CSA TIL B-42A or SPE-1000.

7.4 Support Equipment Battery Charging (not exceeding 24 V and 24 Ah)

7.4.1 Power Distribution for Chargers

- a) Power to multiple chargers shall be from approved multiple outlet devices, such as linear multi-outlet strips; and,
- b) Battery chargers shall not be plugged into multiple (daisy-chained) extension cords; and,
- c) Power bars shall not be plugged into another power bar (daisy-chained).

7.4.2 Charging Area





















- a) the charging area shall be dry and shall have a non-flammable surface; and,
- b) there shall be no flammable materials in proximity to the batteries and chargers; and,
- c) the area shall be adequately ventilated; and,
- d) appropriate spacing shall be provided between batteries while being charged; and,
- e) where a cabinet is used:
 - i) the cabinet shall be ventilated to limit internal temperature rise, incorporating louvres designed to provide convection air flow or incorporate cooling fans, or both; and,
 - ii) the electrical entry/installation shall comply with the CEC Part 1 and bear an electrical approval marking.

































7.4.3 Charging System









- a) consult the manufacturer's operational manual before using the battery system; and,
- b) the charging system shall bear an electrical approval mark that is recognized by the local AHJ; and,
- c) charge only batteries specified by the manufacturer, for usage with the specific battery charger or charging system; and,
- d) adhere to manufacturer's limitations on charge times for each battery and charger.

Appendices













**Appendix A – Accepted Certification Marks.
(Normative re: 4.4.1 and 4.4.3)**

Appendix A – Accepted Certification Marks						
BACL (Bay Area Compliance Laboratories)						
Bureau Veritas Canada (Formerly known as Curtis Straus LLC)						
Canadian Group for Approval Inc. (CGA)						
Canadian Standards Association (CSA)						
DEKRA Certification BV						
Electrical Safety Authority – Field Evaluation (ESAFE)						
FM Approvals LLC						
IAPMO Research and Testing, Inc.						
IAPMO Ventures, LLC dba IAPMO EGS						
ICC NTA, LLC						
International Testing laboratory Inc.						





Appendix A – Accepted Certification Marks						
Intertek Testing Services						
LabTest Certification Inc.						
Eurofins Electrical and Electronic Testing NA, Inc (Formerly known as MET Laboratories Inc)						
Nemko North America, Inc.						
NSF International						
OMNI Environmental Services Inc						
PFS Corporation (operating as PFS TECO)						
QPS Evaluation Services, Inc.						
Quality Auditing Institute						
SGS						
TR Arnold and Associates, Inc.						
TÜV Rheinland of North America, Inc.						

Appendix A – Accepted Certification Marks						
TÜV SÜD America Inc.						
Underwriters' Laboratories of Canada (ULC)						
Underwriters' Laboratories Inc.						

Appendix B – Accepted Field Approval Marks (to SPE-1000).

<p>Quality Auditing Institute</p>				
<p>Q Test Inspection Ltd.</p>				
<p>SEAC Engineering Inc.</p>				
<p>TÜV SÜD America Inc.</p>				
<p>TÜV Rheinland of North America, Inc.</p>				
<p>Underwriters Laboratories of Canada (ULC)</p>				
<p>Vision Integrity Engineering Ltd.</p>				

Appendix C - Component Certification Marks
(Normative re: 4.4.4)

<p>Components bearing any of the following markings are not recognized as approved end-use products. These electrical components may:</p> <ul style="list-style-type: none"> (i) Have restrictions pertaining to their performance or suitability for the product, or application; (ii) Be incomplete in construction; or (iii) Be intended for use as part of or within an approved product or system. 	
Certification Body	Component Marking
Canadian Standards Association (CSA) –	<p>See Note</p> 
Intertek Testing Services	 
Underwriters Laboratories Inc. (UL)	 
<p>Note A component bearing the CSA mark may or may not bear the triangle as shown on the 4 o'clock position. The recommendation is to contact CSA and request complete certification details, including the "Conditions of Acceptability" which is typically included in the CSA Listing.</p>	

Appendix D – European Union and British Marks*
(Informative re: 4.4.2)

CE AND UKCA MARKS



***These marks are not recognized in Canada.**

These marks are manufacturer self-declaration (not 3rd-party certification) marks.

CE marking is intended for national market surveillance enforcement authorities in the EU countries only.

UKCA stands for "UK Conformity Assessed". It is the British version of the European Union's CE marking, applicable for UK laws and the UK market.

CE, as well as the UKCA mark, are not quality indicators or North American recognized certification marks.

**Appendix E - Allowable Ampacity of Flexible Insulated (Multiconductor) Copper Cord
(Normative re: 6.4.3)**

Including prevalent types SJOW, SJOOW, SOW, SOOW **

AWG Common Sizes	2 Current Carrying Conductors	3 Current Carrying Conductors
20	2 *	-
18 §	10	7
16 §	13	10
14 ***	15	13
12 ***	20	16
10 ***	30	25
8	40	35
6	55	45

Based on CEC - 2024, Table 12

* #20 SPT-1 is suitable for 3.6 A when utilised with 5 A fuse protection when used as Christmas-tree cord

** Types SJ, SJO, S, SO etc. and similar types are only acceptable if a component of approved equipment: **shall not be utilised as stand-alone portable cords**

*** Limits with specified ratings from Section 14, Rule 14 - 104 (2) which must be applied.

§ These ampacities are from Table 12 of the CEC and are allowed on circuits protected at 15 A. They should be used with caution.

Note: Many ratings for these cords are lower in value than this table.

**Appendix F - Dual Circuit Fed Receptacle
(Normative re: 6.4.9)**



**DUAL CIRCUIT FED RECEPTACLE
CONNECTION DIAGRAM**

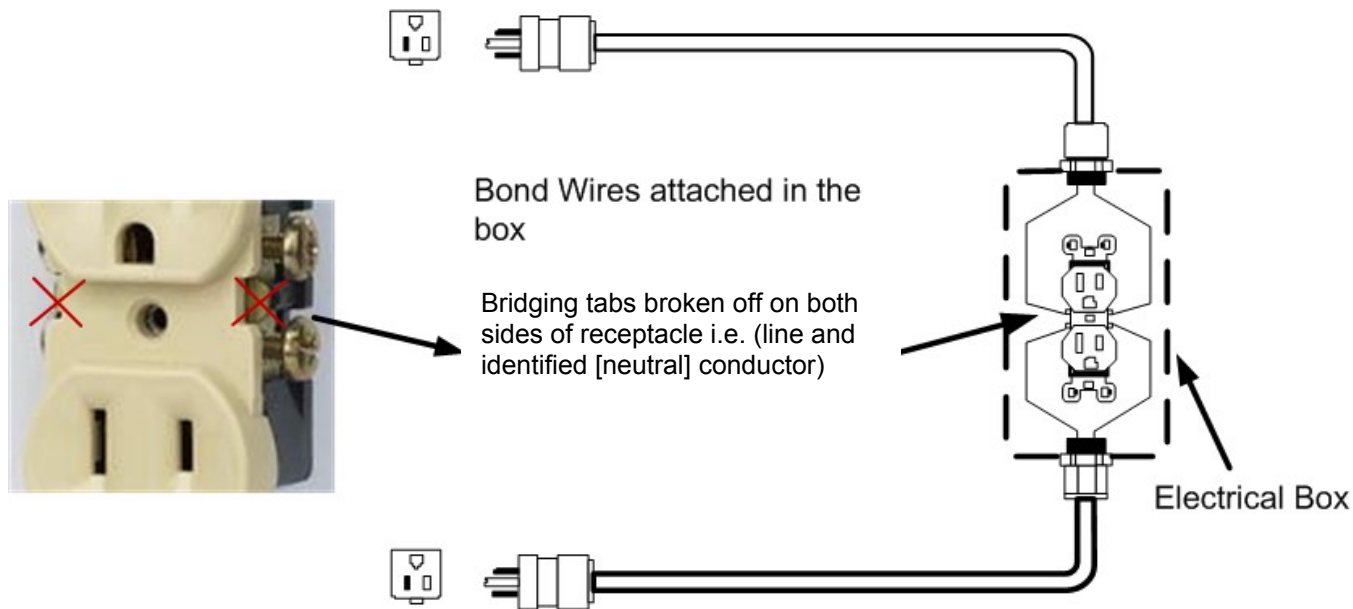

WARNING LABEL

**** Must be affixed under cover plate***

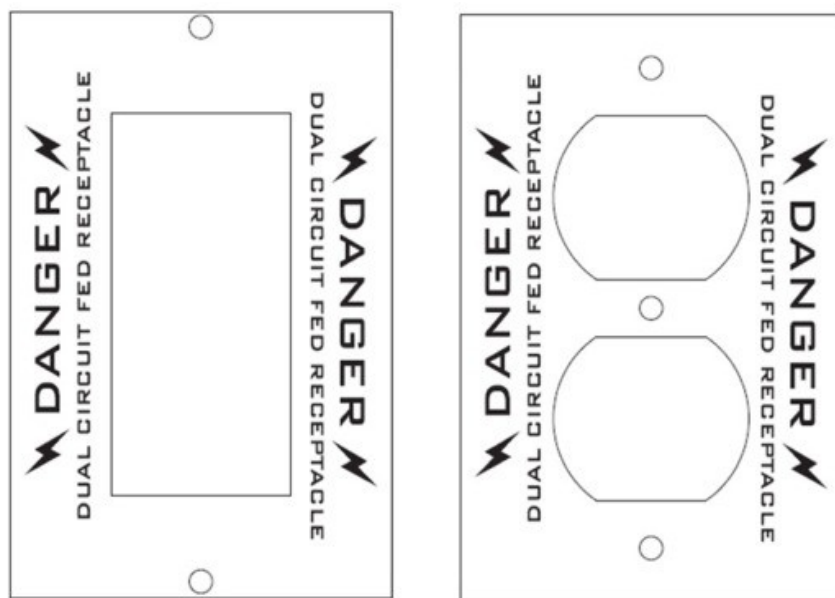

Material – Nomex™

Dimensions - to standard device and cover plate

Appendix G - The Use of Three Phase Distribution Equipment on Single Phase Three Wire Sources (Normative re: 6.2.9)

Figures 1 & 1A – correct practices
Figures 2 & 2A – incorrect practices

Figure 1

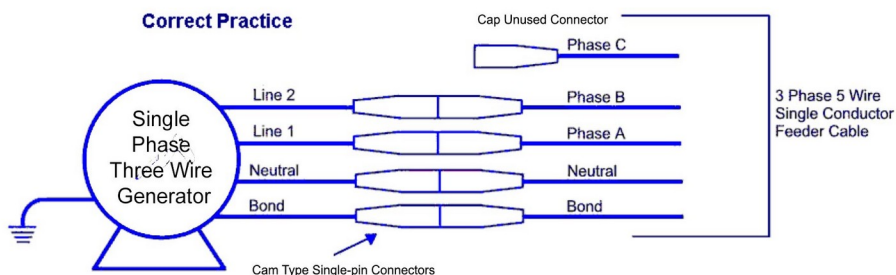

Figure 1A

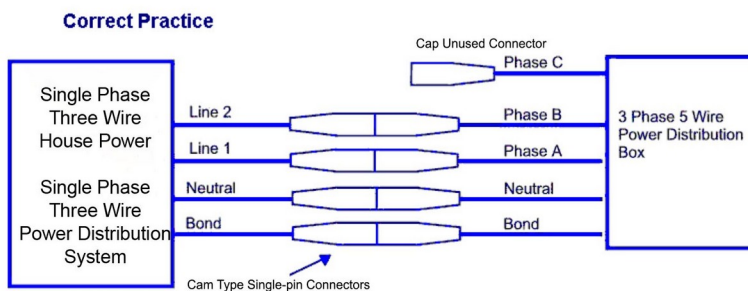

Figure 2

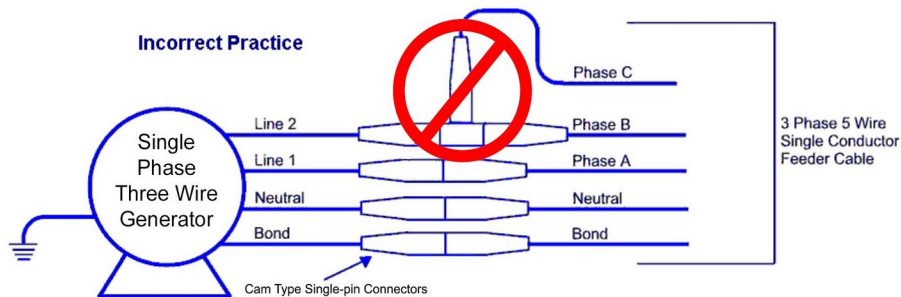
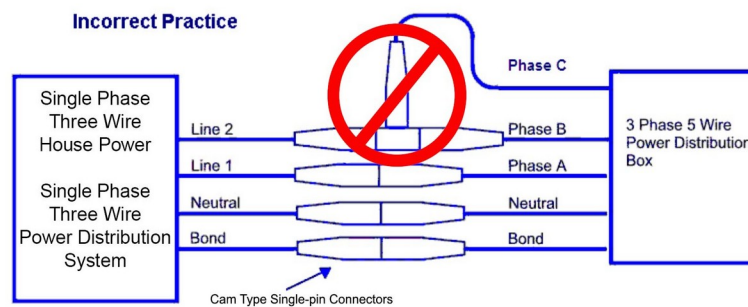

Figure 2A



Appendix H – Correct Mating of Cam-type Single-Pin Connectors (Informative re: 6.2.5.3)

These connectors, utilised correctly, are intended to provide a robust electrical connection for portable power distribution.

The Cam-type single-pin connector is a single-pole separable locking connector designed to carry its rated ampacity when rotated fully, after insertion into its counterpart connector, either in-line, panel mount, or other device. All manufacturers intend that their connectors be FULLY rotated. That means they shall be rotated as far as possible once inserted. A Cam-type single-pin connection may be difficult to insert and require significant force to rotate to full engagement.

Any connector not fully rotated results in a poor connection which can heat, and may also lead to separation of the connection, both of which are improper and unsafe conditions, causing the connector and cable to exceed its' rated operating temperature and in extreme circumstances, cause a fire, coupled with an inability to achieve its' rated ampacity. Non-invasive tooling made for the purpose may be necessary to make the desired rotation on the connector. While the rotation may vary, it is essential that the connectors be firmly rotated, as far as possible.

Cam-type single-pin connections must be FULLY rotated to ensure a solid electrical connection which can operate to its rated ampacity.

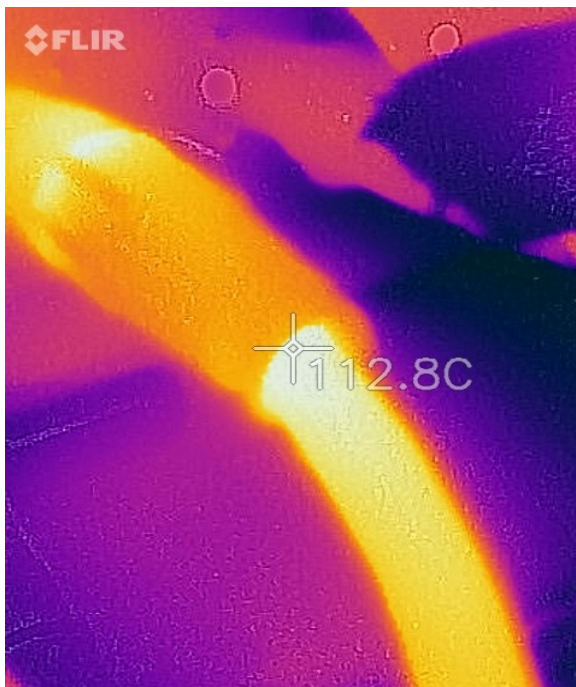

Infra-red scan of a poor Cam-type single-pin connection under load. Rated temperature of the connector lug is 90°C Note that the temperature of the jacket is 112.8°C, and the internal temperature will be higher, exceeding the temperature rating of both lug and cable. Measured load is 225A.

(Photo courtesy of Richard Cadena. Used with permission)

Appendix J – Twofers (Y cords)
(Informative re: 6.4.11)

Twofer – multiconductor assembly with one plug connector (cord cap) to two socket connectors

All twofer components shall have the same ampacity rating as the supply.

The practice of assembling a twofer with a single plug connector with two installed tails incorporating socket connectors into that plug connector, is a misapplication of that (plug connector) device.

Unless the plug connector device is specifically constructed and rated for the installation of two conductors per terminal, the prevalent practice of installing two sets of conductors into the cord cap terminals is unapprovable.

Twofers may be approved by a manufacturer by;

- a) utilising a moulded junction in the middle of the device, or
- b) utilising a plug connector approved for accepting more than one conductor at its terminals, or
- c) as an approved device that is a moulded block incorporating both the supply and the load connections



**Approved
60A Studio
Connector
Twofer**



Approved Stage Pin Twofer



Note certification marks



Misapplication

**Appendix K - Single-Pin Connectors Utilised at Greater Than 150 Volts to Ground
(Informative re: 6.2.8)**

Risk of severe injury to personnel or damage to equipment by connecting to unidentified higher voltage single-pin locking connectors.

Hazard:

Electrical distribution on single-pin locking connectors at voltage(s) above 150 volts to ground may be present in sectors of the entertainment industry utilising exhibition spaces, industrial buildings and/or portable equipment at studios and other locations.

Existing, temporary, or portably installed single-pin locking systems at 416, 480, or 600 volts might not be identified or quarantined (physically isolated in a lockable enclosure).

Coloured taping shall be used for the full length of each connector, excepting the first 30 mm. from the front of the plug connector. Phase colours for these voltages shall be Orange, Brown, Yellow.

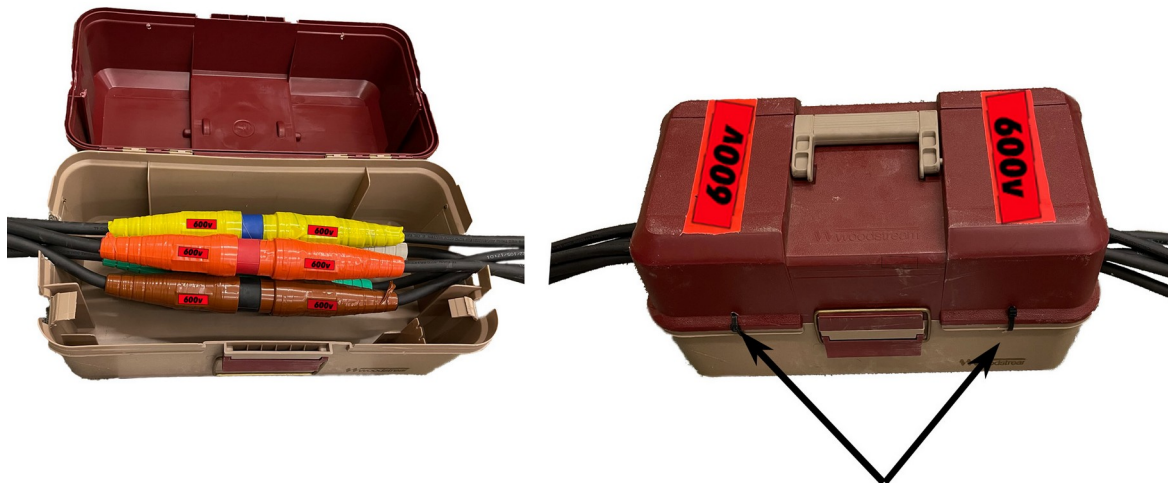

Note: Locked with Zip Ties - tool required to open.

Appendix L – Doorway Insert - Example
(Informative re: 6.5.3)

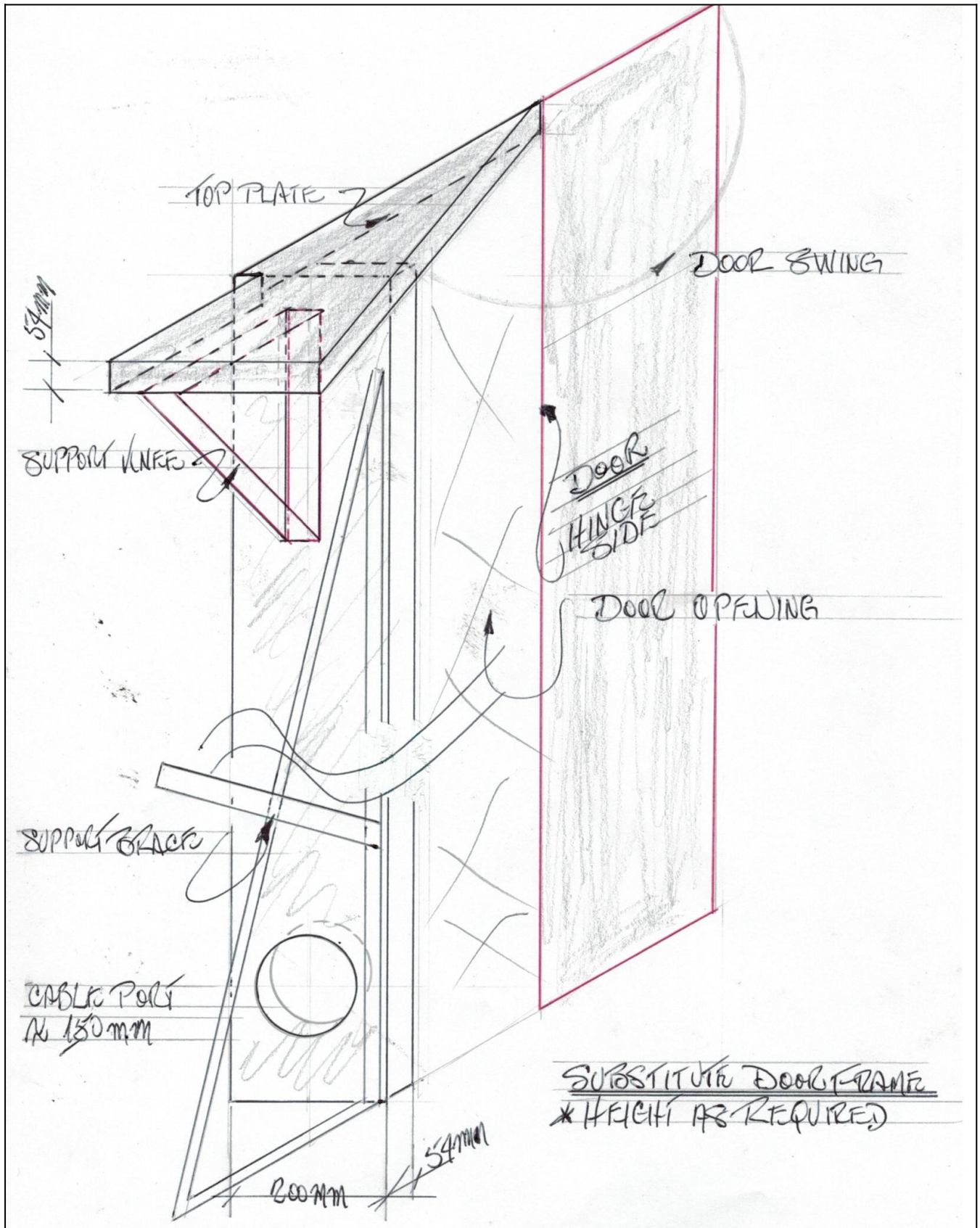

**Appendix M – Industry C of Q Designations
(Informative)**

Entertainment Industry Power Technician: (Ontario Trade 269E); a person holding a valid C of Q in the Entertainment Electrical trade (including but not limited to events, live performance, trade shows, movie (film), video and television productions) who lays out, maintains, connects and repairs a wide range of portable equipment, from portable power feeder cables, branch circuits, luminaires and accessories and apparatus used for the production of entertainment events. *Excludes work on any permanently installed residential, commercial, or industrial electrical system.
(Presently a voluntary trade certification.)*

Full Entertainment Field Safety Representative (FSR) (British Columbia Class B-R): previously named class FE (Full Entertainment). The holder of this valid C of Q may perform temporary installation, maintenance, operation and testing of feeders, branch circuits and electrical equipment. These are typically used for trade shows, exhibits, displays, festivals, conventions, stage, theatre, carnivals, traveling shows, movie or television locations and film or video productions.

Scope of Work: maximum of 400 amps, 750 volts, three-phase power and connecting temporary power to an existing permanent installation.
(A mandatory certification)

The scope of work not authorized under this certificate:

- *includes permanent electrical installation of a regulated product or electrical equipment*
- *electrical work on service conductors and service equipment, and electrical work in hazardous locations*

Limited Entertainment Field Safety Representative (FSR) (British Columbia Class C-R): Previously named class LE (Limited Entertainment).

The holder of this valid C of Q may act as an FSR and perform temporary assembly or interconnection of plug-in wiring systems employed in trade shows, exhibits, displays, festivals, conventions, stage, theatre, carnivals, traveling shows, movie and television locations, and film or video productions or similar venues.
(A mandatory certification)

Scope of Work: a maximum of 240 volts, 100 amps, three-phase power, utility supplied or a maximum of 240 volts, 200 amps, three-phase power, generator supplied.

The scope of work not authorized under this certificate includes:

- *regulated work (electrical work) for the permanent electrical installation of a regulated product (electrical equipment),*
- *electrical work in hazardous locations.*

**Appendix N - Reference Standards and Guidelines
(Informative)**

- **CEC** Part 1, 2024, 26th edition
- **Provincial Electrical Code(s) 2024**
- **SPE-1000-21**, Model Code for the Field Evaluation of Electrical Equipment
- **C22.2 NO. 41:22**, Grounding and Bonding Equipment
- **C22.2 NO. 96:23**, Portable Power Cables
- **C22.2 NO. 100:14 (R2024)**, Motors and Generators
- **C22.2 NO. 166:15 (R2020)**, Stage & Studio Luminaires
- **C22.2 NO. 300:18 (R2023)**, Portable Power Equipment
- **C22.2 No. 1691:21**, Single Pole Locking-Type Separable Connectors
- **CSA Z195:14 (R2023)**, Protective Footwear
- **CSA Z462:21**, Workplace Electrical Safety
- **ANSI E1.28-2011 (R2021)**, Guidance on Planning Followspot Positions in Places of Public Assembly
- **ANSI E1.51-2024**, THE SELECTION, INSTALLATION, AND USE OF SINGLE-CONDUCTOR PORTABLE POWER FEEDER CABLE SYSTEMS FOR USE AT 600 VOLTS NOMINAL OR LESS FOR THE DISTRIBUTION OF ELECTRICAL ENERGY IN THE TELEVISION, FILM, LIVE PERFORMANCE AND EVENT INDUSTRIES IN CANADA
- **ANSI E1.53-2016**, OVERHEAD MOUNTING OF LUMINAIRES, LIGHTING ACCESSORIES, AND OTHER PORTABLE DEVICES: SPECIFICATION AND PRACTICE
- **ANSI E1.58-2017** - Electrical Safety Standard for Portable Stage and Studio Equipment Used Outdoors
- **ANSI E1.66-2020**, Safety Standard for Followspot Positions Erected for Short-term Use in Entertainment Venues
- **ANSI E1.80-2024**, Pinout Configuration Types for Special-Purpose Multi-circuit Cable Systems

<i>19 pin circular connector multi-circuit systems. Several different pinouts are used for 19 pin circular connectors in the entertainment industry. This standard identifies acceptable configurations.</i>
--
- **OHSA**: Occupational Health and Safety Act – by jurisdiction (Province or Territory)

Tables

Table 1 - Overcurrent Protection for Portable Power Cable * (Normative re: 6.2.6.1)			AHJ
Conductor Size AWG	Protect at	Description	
4	100 A	"Load Centre" (Bundled)	
2	175 A	"Seaway" (Bundled)	
2	200 A **	"Seaway" (Bundled)	
1/0	200 A	Singles – Not bundled	
2/0	250 A	Singles – Not bundled	
4/0	400 A	Singles – Not bundled	
* Refer to Table 12A of the CEC, column ≤ 2 kV non shielded			
** Allowed as easement in BC			
<i>Note: Values are single conductor free air ratings without provision for bundling or voltage drop.</i>			

Table 2 - 19 Pin Circular Connector Pin Designation – ANSI E1.80 120V Type U
(Normative re: 6.3.2)
Refer to Table 2A for designations for nominal 220V configurations

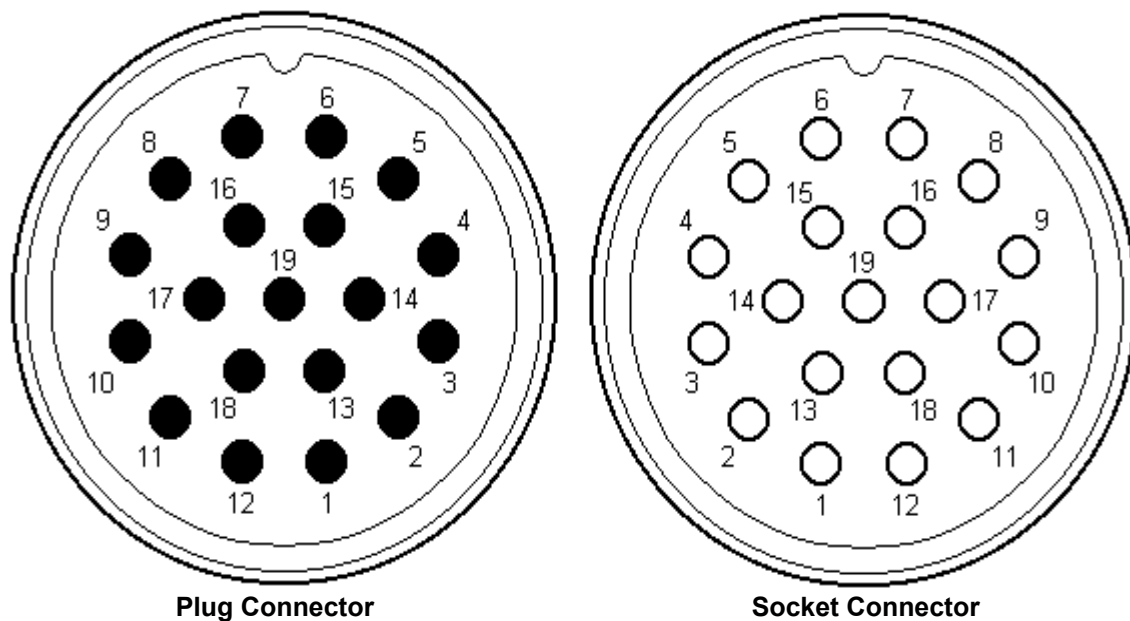

19 Pin Circular Connector Viewed from Solder Side

ANSI E1.80 120V Type U			
Circuit Number	Line	Identified Conductor (Neutral)	Bond
1	Pin 1	Pin 2	Pin 13
2	Pin 3	Pin 4	Pin 14
3	Pin 5	Pin 6	Pin 15
4	Pin 7	Pin 8	Pin 16
5	Pin 9	Pin 10	Pin 17
6	Pin 11	Pin 12	Pin 18

Pin 19 may be utilised in bonding the connector shell.

Table 2A - 19 Pin Circular Connector Designations
 (Normative re: 6.3.2)
TABLE 1 and TABLE 2 from ANSI E1.80

TABLE 1 NORTH AMERICA										
Pin	120V TYPE U		208V TYPE C		240V TYPE C		208V TYPE D		208V TYPE E	
	USITT RP-1		BS7909 C		Derivative of 208V TYPE C		BS7909 D		BS7909 E	
	CIRCUIT	L/N/G	CIRCUIT	L/N/G	CIRCUIT	L/N/G	CIRCUIT	L/N/G	CIRCUIT	L/N/G
1	1	L	1	L	1	L	1	L1	1	L1
2	1	N	1	L	1	L	2	L1	2	L1
3	2	L	2	L	2	L	3	L2	1	L2
4	2	N	2	L	2	L	1	L2	2	L2
5	3	L	3	L	3	L	2	L3	3	L3
6	3	N	3	L	3	L	3	L3	4	L3
7	4	L	4	L	4	L	4	L1	3	L1
8	4	N	4	L	4	L	5	L1	4	L1
9	5	L	5	L	5	L	6	L2	5	L2
10	5	N	5	L	5	L	4	L2	6	L2
11	6	L	6	L	6	L	5	L3	5	L3
12	6	N	6	L	6	L	6	L3	6	L3
13	G1	G	G1	G	G1	G	G1	G	G1	G
14	G2	G	G2	G	G2	G	G2	G	G2	G
15	G3	G	G3	G	G3	G	G3	G	G3	G
16	G4	G	G4	G	G4	G	G4	G	G4	G
17	G5	G	G5	G	G5	G	G5	G	G5	G
18	G6	G	G6	G	G6	G	G6	G	G6	G
19	NC	NC	NC	NC	NC	NC	NC	NC	NC	NC

TABLE 2 EUROPE		
230V TYPE A		Pin
BS7909 A		
DIN15765		
CIRCUIT	L/N/G	
1	L	1
1	N	2
2	L	3
2	N	4
3	L	5
3	N	6
4	L	7
4	N	8
5	L	9
5	N	10
6	L	11
6	N	12
G1	G	13
G2	G	14
G3	G	15
G4	G	16
G5	G	17
G6	G	18
NC	NC	19

Table Key:

L = Ungrounded Circuit Conductor; commonly known as “Hot” or “Phase”.

N = Grounded Circuit Conductor; commonly known as “Neutral”.

NC = no connection

G = Bonding (Grounding) Conductor; commonly known as “Ground” in North America and “Earth” in Europe.

120V Type U North American pinout configuration originated by USITT RP-1.

208V Type C North American pinout configuration also found in BS7909 Annex H as Type C.

240V Type C North American pinout configuration - a voltage derivative of 208V TYPE C.

208V Type D North American pinout configuration also found in BS7909 Annex H as Type D.

208V Type E North American pinout configuration also found in BS7909 Annex H as Type E.

230V Type A European pinout configuration found in BS7909 Annex H as Type A and DIN15765 Table 3 No 7.

Marking

When deployed, each multi-circuit, multipole connector that is part of a Special-Purpose Multicircuit Cable System shall be clearly marked with voltage, a reference to ANSI E1.80, and the type designation.

Examples:

120V ANSI E1.80 Type U

208V ANSI E1.80 Type C

240V ANSI E1.80 Type C

Table 2A - Marking Examples

